

NSAI

ECE TYPE-APPROVAL CERTIFICATE



Communication Concerning:² Approval granted
~~Approval extended~~
~~Approval refused~~
~~Approval withdrawn~~
~~Production definitively discontinued~~

Of a type of ~~vehicle~~/component/~~separate technical unit~~² with regard to Regulation No. 10.
Of a type of electrical/electronic sub-assembly² with regard to Regulation No.10.

Approval No: **E24*10R06/02*4572*00**

Reason for extension:

-N/A

1. Make (trade name of manufacturer):

HUAZHAO

2. Type and general commercial description:

HZ-W8010
LED LAMP LIGHT

Variant(s):

HZ-W8012, HZ9001, HZ9002, HZ9003,
HZ9004, HZ1021D, HZ1022D, HZ1031,
HZ1040S, HZ7011, HZ7010, HZ9006,
HZ-8011, HZ1050, HZ30128, HZ9007,
HZ1040F, HZ9005, HZ1040D, HZ2098,
HZ-W8010

3. Means of identification of type, if marked on the ~~vehicle~~/
component/separate technical unit²:

Approval mark

3.1 Location of that marking:

Marked on Lens, See Drawings of the
ESA

4. Category of vehicle:

N/A

5. Name and address of manufacturer:

Foshan Huazhao Electronics Co.,LTD
6th floor, C Building, No. 1 Xinfeng
Road.Songgang Songxia Industrial
Park, Shishan Town, Nanhai District,
FoshanCity/528225, Guangdong
Province, China

6. In the case of components and separate technical units,
location and method of affixing of the approval mark:

Marked on Lens, See Drawings of the
ESA

7. Address(es) of assembly plant(s):

Same as address of the manufacturer

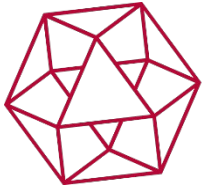

NSAI

Approval No: E24*10R06/02*4572*00

8. Additional information (where applicable): *See appendix below*
9. Technical service responsible for carrying out the tests: *CETOC Technical Service srl
Via della Bufalotta, 374,
00139 Roma*
10. Date of test report: *10.04.2023*
11. Number of test report: *CN-112-17-87-COM23-06482-IR*
12. Remarks (if any): *See Appendix below*
13. Place: *Dublin*
14. Date: *04th May, 2023*
15. Signature:



16. The index to the information package lodged with the approval authority, which may be obtained on Request, is attached.

-
1. Distinguishing number of the country which issued/extended/refused or withdrawn approval.
(see Regulation, provisions on approval).
2. Strike out what does not apply.

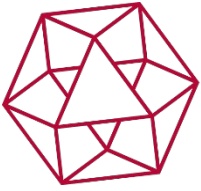

NSAI

Approval No: E24*10R06/02*4572*00

Appendix

To type-approval communication concerning the type approval of an electrical/electronic sub-assembly under Regulation No.10.

1. Additional information
 - 1.1. Electrical system rated voltage: **DC 12/24V, negative ground**
 - 1.2. This ESA can be used on any vehicle type with the following restrictions: **See manufacturer's specifications.**
 - 1.2.1 Installation conditions, if any: **See manufacturer's specifications.**
 - 1.3. This ESA can only be used on the following vehicle types: **N/A**
 - 1.3.1 Installation conditions, if any: **N/A**
 - 1.4. The specific test method(s) used and the frequency ranges covered to determine immunity were: **Bulk Current Injection Method:
Frequency: (20 – 400 MHz)
Absorber Chamber Test:
Frequency: (400 – 2000 MHz)**
 - 1.5. Laboratory accredited to ISO 17025 and recognized by the Approval Authority responsible for carrying out the tests: **CETOC Technical Service srl**
2. Remarks: **N/A**

Appendix to type-approval communication concerning the type approval of a vehicle under Regulation No.10.

1. Additional information
2. Electrical system rated voltage: **N/A**
3. Type of bodywork: **N/A**
4. List of electronic systems installed in the tested vehicle(s) not limited to the items in the information document: **N/A**
 - 4.1. Vehicle equipped with 24 GHz short-range radar equipment (yes/no/optional)²: **N/A**
5. Laboratory accredited to ISO 17025 and recognized by the Approval Authority responsible for carrying out the tests: **N/A**
6. Remarks: **N/A**

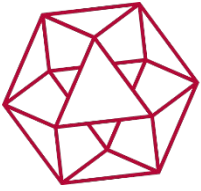

NSAI

Approval No: E24*10R06/02*4572*00

Index to the Information Package

Date of issue:	<i>04th May, 2023</i>
Date of latest amendment:	<i>N/A</i>
Reason for extension/revision:	<i>N/A</i>
1. Additional conditions, and advisory notes on legal alternatives.	
2. Test report(s)	
- numbers(s):	<i>CN-112-17-87-COM23-06482-IR</i>
- date of issue:	<i>10.04.2023</i>
- date of latest amendment:	<i>N/A</i>
3. Information document	
- number(s):	<i>HZ-W8010-00</i>
- date of issue:	<i>31.03.2023</i>
- date of latest amendment:	<i>N/A</i>
Documentation:	<i>27 pages</i>

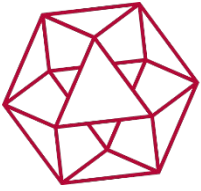

NSAI

Approval No: E24*10R06/02*4572*00

Appendix: **Additional conditions, and advisory notes on legal alternatives**

A: Additional conditions:

1. The attached technical report, with any of its attachments, forms part of this Type Approval certificate.
2. Each device from series production shall be to the measurements specified in the attached drawings, and shall be manufactured only from the materials specified in the Approval documents.
3. Changes in the type are permitted only with the explicit permission of NSAI. Breaches of this requirement will lead to a withdrawal of the Type Approval, and in addition may be subject to criminal prosecution.
4. At regular intervals, any tests or associated checks prescribed by the applicable legislation to verify continued conformity with the approved type shall be carried out. The manufacturer shall demonstrate compliance with this by submitting to NSAI evidence of adequate arrangements and documented control plans for each type approved.
5. Any set of samples or test pieces showing evidence of non-conformity shall give rise to further sampling and testing and all steps shall be taken to restore conformity of production.
6. This Type Approval will expire when it is surrendered by the holder, or withdrawn by NSAI, or when the approved type no longer conforms to legal requirements. The recall of the Type Approval can be issued by NSAI when the conditions required for the issuing or continuation of the Type Approval are no longer current, or when the Approval holder is in breach of the duties attached to the Type Approval, or when it is established that the approved type no longer meets the requirements of traffic safety.
7. Changes in the company name, address or manufacturing site, as well as in any of the sales or other agents specified in the issuing of the approval must immediately be notified to NSAI.
8. The duties imposed by the issuing of this certificate are not transferable. The legal protection of third parties is not affected by this certificate.
9. When the manufacture or sale of the system, component or separate technical unit has not been started within one year of the date of issue of this certificate, then NSAI is to be informed. This requirement also applies when the manufacture or sale has been halted for more than one year, or when it ought to have been halted for more than one year. The initial commencement of manufacture or sale, or the resumption of manufacture or sale, shall then be notified to NSAI within one month of commencement or resumption.

B: Legal Options:

Any objection to the requirements set out in this certificate shall be made within one month of the date of issue. The objection shall be made, in writing, to NSAI in Dublin.



CETOC TS

CETOC Technical Service srl
Via della Bufalotta, 374,
00139 Roma

Inspection Report Nr.: CN-112-17-87-COM23-06482-IR
Manufacturer: Foshan Huazhao Electronics Co.,LTD
Type: HZ-W8010

This inspection report shall not be reproduced except in full, without written approval of the technical service.



ISP N° 0184 E

Membro degli Accordi di Mutuo Riconoscimento
EA, IAF e ILAC

Signatory of EA, IAF and ILAC
Mutual Recognition Agreements

Electromagnetic Compatibility – ESA

0. Legislation:

0.1. Requirements according to : UNECE Regulation 10.06 to Supplement 2

1. General

1.1. Reason for Inspection Report : New approval / ~~Extension of approval~~ / ~~Test report only~~ / COP
1.2. Manufacturer's Representative(s) : No attendance
1.3. CETOC TS Representative(s) : Xiaoli Li
1.4. Location of Test : GuangZhou ShunTai Quality Technical Service Co., Ltd.
Room 206A, 2F, 4# Plant, No.63 Punan Road, Huangpu District,
Guangzhou, China, 510760
1.5. Data of test : 08/04/2023

2. Manufacturer Details

2.1. Make : HUAZHAO
2.2. Type : HZ-W8010
2.3. Variant/Version : HZ-W8012, HZ9001, HZ9002, HZ9003, HZ9004, HZ1021D,
HZ1022D, HZ1031, HZ1040S, HZ7011, HZ7010, HZ9006, HZ-8011,
HZ1050, HZ30128, HZ9007, HZ1040F, HZ9005, HZ1040D,
HZ2098, HZ-W8010
2.4. Commercial Name : LED LAMP LIGHT
2.5. Category : Component
2.6. Name and Address of manufacturer : Foshan Huazhao Electronics Co.,LTD
6th floor, C Building, No. 1 Xinfeng Road.Songgang Songxia
Industrial Park, Shishan Town, Nanhai District, FoshanCity/528225,
Guangdong Province, China

3. Conclusion:

3.1. Final conclusion of the inspection: The above mentioned type was tested in accordance with the above mentioned legislation and was found to comply in all respects. This Inspection report relates only to the items tested.

Signature:

Name: : Xiaoli Li

Massimo Peraboni

Position: : Type Approval Engineer

Tech. Mgr.

Place and date: : Guangzhou,10/04/2023

Roma, 10/04/2023

4. List of annexes:

Annex Nr.	Page Nr.	Subject
Annex I	2	: Appendix 1 - Test report history
Annex II	2	: Appendix 2 – General specification
Annex III	4	: Appendix 3 – Inspection results
Annex IV	12	: Appendix 4 – Test results



CETOC TS

CETOC Technical Service srl
Via della Bufalotta, 374,
00139 Roma

Inspection Report Nr.: CN-112-17-87-COM23-06482-IR
Manufacturer: Foshan Huazhao Electronics Co.,LTD
Type: HZ-W8010

This inspection report shall not be reproduced except in full, without written approval of the technical service.



ISP N° 0184 E

Membro degli Accordi di Mutuo Riconoscimento
EA, IAF e ILAC

Signatory of EA, IAF and ILAC
Mutual Recognition Agreements

APPENDIX 1 - TEST REPORT HISTORY

List this report and previous reports, with extension details.

Inspection Report Number	Reason for Extension	Date of Issue
CN-112-17-87-COM23-06482-IR	N/A	10/04/2023

APPENDIX 2 – GENERAL SPECIFICATION

1. **Worst Case Rationale** : All variants have the same electronic circuit design and the same component list for each PCB, the differences among them are the light Appearance and size.
The model HZ-W8010 has been tested under of rated voltage of 12/24V.

2. **Significant Interpretations, Alternative Test Methods, New Technologies** : N/A

3. Summary of test results

3.1. Applicability :

	PASS	FAIL	N/A
Radiated Emissions:	<input checked="" type="checkbox"/>	<input type="checkbox"/>	<input type="checkbox"/>
Radiated Immunity:	<input checked="" type="checkbox"/>	<input type="checkbox"/>	<input type="checkbox"/>
BCI Immunity:	<input checked="" type="checkbox"/>	<input type="checkbox"/>	<input type="checkbox"/>
Free Field Immunity:	<input checked="" type="checkbox"/>	<input type="checkbox"/>	<input type="checkbox"/>
150 mm Stripline Immunity:	<input type="checkbox"/>	<input type="checkbox"/>	<input checked="" type="checkbox"/>
800 mm Stripline Immunity:	<input type="checkbox"/>	<input type="checkbox"/>	<input checked="" type="checkbox"/>
Transient Testing:	<input checked="" type="checkbox"/>	<input type="checkbox"/>	<input type="checkbox"/>

4. Component Specification

Component Part Number:	HZ-W8010
------------------------	----------

5. Facility and Equipment Checks

5.1. Calibration certificates checked and valid, recorded in the following table : Conform

5.2. All instruments are equipped with identification label : Yes

5.3. Calibration certificates are complete of calibration-chain with detailed information regarding primary used. : Yes

5.4. Is the anechoic/semi-anechoic chamber correctly set up in all its electrical/mechanical parts to ensure the validity of the measurements? : Yes



CETOC TS

CETOC Technical Service srl
Via della Bufalotta, 374,
00139 Roma

Inspection Report Nr.: CN-112-17-87-COM23-06482-IR
Manufacturer: Foshan Huazhao Electronics Co.,LTD
Type: HZ-W8010

This inspection report shall not be reproduced except in full, without written approval of the technical service.



ISP N° 0184 E

Membro degli Accordi di Mutuo Riconoscimento
EA, IAF e ILAC

Signatory of EA, IAF and ILAC
Mutual Recognition Agreements

Equipment	Serial / Certificate No.	Calibration due*
ALSE ROOM	CN 2GB22052344006-0006	26/05/2025
EMI receiver	CN J202206020680A-0007	06/07/2023
L.I.S.N.	CN J202206020680A-0015	06/07/2023
L.I.S.N.	CN J202206020680A-0016	06/07/2023
Biconical antenna	CN J202206020680-02-0005	31/07/2023
Log-periodic antenna	CN J202206020680-04-0001	28/08/2023
Supply Voltage Change Simulator	CN J202206020680A-0001	06/07/2023
Load dump wave simulator	CN J202206020680A-0002	06/07/2023
Transient pulse disturbance simulator	CN J202206020680A-0003	06/07/2023
Current Injection Clamp	CN J202206020680A-0012	06/07/2023
Digital phosphor oscilloscope	CN 1GA22042037623-0002	21/04/2023

*Specify calibrated date + (interval) or calibration due date.



CETOC TS

CETOC Technical Service srl
Via della Bufalotta, 374,
00139 Roma

Inspection Report Nr.: CN-112-17-87-COM23-06482-IR
Manufacturer: Foshan Huazhao Electronics Co.,LTD
Type: HZ-W8010

This inspection report shall not be reproduced except in full, without written approval of the technical service.



ISP N° 0184 E

Membro degli Accordi di Mutuo Riconoscimento
EA, IAF e ILAC

Signatory of EA, IAF and ILAC
Mutual Recognition Agreements

APPENDIX 3 – INSPECTION RESULTS

		PASS	FAIL	N/A
Radiated Emissions				
CISPR25, 4.5.	Measuring equipment complies with CISPR 16-1-4 (2010).	<input checked="" type="checkbox"/>	<input type="checkbox"/>	<input type="checkbox"/>
Test Location				
Ann 7, 3.1. Ann 7, 3.3.	Test performed in: - A.L.S.E (Absorber-lined Shielded Enclosure)* - O.A.T.S (Open Area Test Site)* <i>*Strikethrough, as appropriate.</i>	<input checked="" type="checkbox"/>	<input type="checkbox"/>	<input type="checkbox"/>
Ann 7, 3.3.	O.A.T.S level is a clear area, free from electromagnetic reflecting surfaces, within a circle of 15 m minimum radius.	<input type="checkbox"/>	<input type="checkbox"/>	<input checked="" type="checkbox"/>
Ann 7, 3.3.	Measuring equipment is outside 15 m minimum radius circle.	<input type="checkbox"/>	<input type="checkbox"/>	<input checked="" type="checkbox"/>
Ann 7, 3.4.	Ambient noise is at least 6 dB below reference limits, in either case.	<input checked="" type="checkbox"/>	<input type="checkbox"/>	<input type="checkbox"/>
Test Arrangements				
CISPR25, 4.4.2.	EUT and antenna are more than 2 m from the walls and ceiling, and 1 m from the nearest absorber material.	<input checked="" type="checkbox"/>	<input type="checkbox"/>	<input type="checkbox"/>
CISPR25, 6.1.1.	Ground plane is 900 ± 50 mm high and made from 0.5 mm thick copper, brass or galvanised steel.	<input checked="" type="checkbox"/>	<input type="checkbox"/>	<input type="checkbox"/>
CISPR25, 6.1.1.	Ground plane is at least 2,000 mm length x 1,000 mm width.	<input checked="" type="checkbox"/>	<input type="checkbox"/>	<input type="checkbox"/>
CISPR25, 6.4.2.3.	ESA and harness are supported at 50 ± 5 mm above the ground plane on low relative permittivity material.	<input checked="" type="checkbox"/>	<input type="checkbox"/>	<input type="checkbox"/>
CISPR25, 6.4.2.3.	Face of the ESA is within 200 mm ± 10 mm from the edge of the ground plane.	<input checked="" type="checkbox"/>	<input type="checkbox"/>	<input type="checkbox"/>
CISPR25, 6.4.2.4.	Length of test harness, parallel to the front of the ground plane, is 1,500 ± 75 mm and does not exceed 2,000 mm.	<input checked="" type="checkbox"/>	<input type="checkbox"/>	<input type="checkbox"/>
CISPR25, 6.4.2.4.	Long segment of test harness is located parallel to the edge of the ground plane, facing the antenna at a distance of 100 ± 10 mm from the edge.	<input checked="" type="checkbox"/>	<input type="checkbox"/>	<input type="checkbox"/>
CISPR25, 6.1.2.	Power supply is Artificial Network (AN) rated at 5 Ω/50 µH.	<input checked="" type="checkbox"/>	<input type="checkbox"/>	<input type="checkbox"/>
CISPR25, 6.1.2.	EUT is: - Remotely grounded (vehicle power return line longer than 200 mm): two artificial networks are required, one for the positive supply line and one for the power return line* - Locally grounded (vehicle power return line 200 mm or shorter): one artificial network is required for the positive supply* <i>*Strikethrough, as appropriate.</i>	<input checked="" type="checkbox"/>	<input type="checkbox"/>	<input type="checkbox"/>
CISPR25, 6.1.2.	Case of the ESA is: - Grounded, simulating actual vehicle configuration* - Not grounded, simulating actual vehicle configuration* <i>*Strikethrough, as appropriate.</i>	<input checked="" type="checkbox"/>	<input type="checkbox"/>	<input type="checkbox"/>
CISPR25, 6.1.2.	AN is electrically bonded to the ground plane.	<input checked="" type="checkbox"/>	<input type="checkbox"/>	<input type="checkbox"/>



CETOC TS

CETOC Technical Service srl
Via della Bufalotta, 374,
00139 Roma

Inspection Report Nr.: CN-112-17-87-COM23-06482-IR
Manufacturer: Foshan Huazhao Electronics Co.,LTD
Type: HZ-W8010

This inspection report shall not be reproduced except in full, without written approval of the technical service.



ISP N° 0184 E

Membro degli Accordi di Mutuo Riconoscimento
EA, IAF e ILAC

Signatory of EA, IAF and ILAC
Mutual Recognition Agreements

Antenna

<i>CISPR25, 6.4.2.6.</i>	Height of the phase centre is 100 ± 10 mm above the ground plane.	<input checked="" type="checkbox"/>	<input type="checkbox"/>	<input type="checkbox"/>
<i>CISPR25, 6.4.2.6.</i>	No part of any antenna radiating element is closer than 250 mm to the floor.	<input checked="" type="checkbox"/>	<input type="checkbox"/>	<input type="checkbox"/>
<i>CISPR25, 6.4.2.6.</i>	Radiating elements of the measuring antenna are not closer than 1,000 mm to any absorber material, except that used on the floor, and are not closer than 2,000 mm to the walls or ceiling of the shielded enclosure.	<input checked="" type="checkbox"/>	<input type="checkbox"/>	<input type="checkbox"/>
<i>CISPR25, 6.4.2.6.</i>	Phase centre (for biconical) or tip (for log-periodic) is 1,000 ± 50 mm from the harness.	<input checked="" type="checkbox"/>	<input type="checkbox"/>	<input type="checkbox"/>
<i>CISPR25, 6.4.2.6.</i>	Antenna calibrated for this distance to correct measuring point (phase centre or tip).	<input checked="" type="checkbox"/>	<input type="checkbox"/>	<input type="checkbox"/>
<i>CISPR25, 6.4.2.6.</i>	Phase centre of the antenna is in line with the centre of the longitudinal part of the wiring harness.	<input checked="" type="checkbox"/>	<input type="checkbox"/>	<input type="checkbox"/>
<i>Ann 7, Ann 8, 4.3.</i>	Pre-test sweep supplied to show compliance throughout frequency range 30 to 1,000 MHz.	<input checked="" type="checkbox"/>	<input type="checkbox"/>	<input type="checkbox"/>
<i>Ann 7, Ann 8, 4.3.</i>	Test frequencies chosen from pre-test data.	<input checked="" type="checkbox"/>	<input type="checkbox"/>	<input type="checkbox"/>

Narrowband Test Results

<i>Ann 8, 2.</i>	Operational mode of ESA: Normal operation	<input checked="" type="checkbox"/>	<input type="checkbox"/>	<input type="checkbox"/>
<i>Ann 8, 4.2.</i>	Detector used and bandwidth: Average, 120kHz	<input checked="" type="checkbox"/>	<input type="checkbox"/>	<input type="checkbox"/>
<i>6.6.2.</i>	ESA meets narrowband emissions limits, with both vertical and horizontal polarisations.	<input checked="" type="checkbox"/>	<input type="checkbox"/>	<input type="checkbox"/>

Broadband Test Results

<i>Ann 7, 2.</i>	Operational mode of ESA: Normal operation	<input checked="" type="checkbox"/>	<input type="checkbox"/>	<input type="checkbox"/>
<i>Ann 7, 4.2.</i>	Detector used and bandwidth: Quasi peak, 120kHz	<input checked="" type="checkbox"/>	<input type="checkbox"/>	<input type="checkbox"/>
<i>6.5.2.</i>	ESA meets broadband emissions limits, with both vertical and horizontal polarisations.	<input checked="" type="checkbox"/>	<input type="checkbox"/>	<input type="checkbox"/>

Radiated Immunity

Test Method(s) used and Frequency Range(s)

<i>ISO11452-4</i>	BCI frequency range between 20 and 400 MHz:	<input checked="" type="checkbox"/>	<input type="checkbox"/>	<input type="checkbox"/>
<i>ISO11452-2</i>	Free field frequency range between 400 and 2,000 MHz:	<input checked="" type="checkbox"/>	<input type="checkbox"/>	<input type="checkbox"/>
<i>ISO11452-3</i>	TEM cell frequency range between 20 and 200 MHz:	<input type="checkbox"/>	<input type="checkbox"/>	<input checked="" type="checkbox"/>
<i>ISO11452-5</i>	150 mm stripline frequency range between 20 and 400 MHz:	<input type="checkbox"/>	<input type="checkbox"/>	<input checked="" type="checkbox"/>
<i>ISO11452-5</i>	800 mm stripline frequency range between 20 and 2,000 MHz:	<input type="checkbox"/>	<input type="checkbox"/>	<input checked="" type="checkbox"/>



This inspection report shall not be reproduced except in full, without written approval of the technical service.

Maximum frequency step sizes do not exceed:

Frequency Band (MHz)	Linear Steps (MHz)	Log Steps (%)	Actual Steps Used
20 - 200	5	5	5%
200 - 400	10	5	5%
400 - 1000	20	2	2%
1000 - 2000	40	2	2%

Test Arrangements (General)

- Ann 9, 2.2. Operational mode of ESA:
 Normal operation
- Ann 9, 2.3. Extraneous equipment in place during calibration.
- Ann 9, 2.4. Test equipment used is the same as for calibration.
- Ann 9, 2.5. Loads and actuators are as realistic as possible.
- Ann 9, 2.5. Case of ESA is:
- ~~Grounded, simulating actual vehicle configuration*~~
- Not grounded, simulating actual vehicle configuration*
*Strikethrough, as appropriate.
- Ann 9, 3.1. Test frequency range is 20 to 2,000 MHz.
- Ann 9, 3.1. Test signal is R.F. sine wave amplitude, modulated by a 1 kHz sine wave at a modulation depth of 0.8 ± 0.04 , in the 20 - 800 MHz band and pulse modulation (time on 577 μ s, period 4,600 μ s) in the 800 - 2,000 MHz band.
- 6.8.2.1. Pre-test sweep supplied to show compliance throughout frequency range 20 to 2,000 MHz.
- Ann 9, 3.2. Test frequencies chosen from pre-test data.
- 6.8.2.2. No degradation of immunity related functions during the tests.

BCI Immunity

- ISO11452-4, 5. Shielded area used:
 Yes
- ISO11452-4, 8.3.2.1. Forward power used to achieve specified current.

Installation of ESA under Test

- Ann 9, 4.3.2. Current probe located 150 ± 10 mm from ESA connectors.
- Ann 9, 4.3.2. ESA installed:
- ~~In a vehicle, as per ISO 11451-4*~~
- On a ground plane, as per ISO 11452-4*
*Strikethrough, as appropriate.
- ISO11452-4, 7.1. Ground plane is made from at least 0.5 mm thick copper, brass or galvanised steel.
- ISO11452-4, 7.1. Minimum width of the ground plane is 1,000 mm and the minimum length is 1,500 mm, or length of the entire underneath of equipment plus 200 mm, whichever is greater.



ISO11452-4, 7.1.	Height of the ground plane is 900 ± 100 mm.	<input checked="" type="checkbox"/>	<input type="checkbox"/>	<input type="checkbox"/>
ISO11452-4, 7.1.	Ground plane is bonded to the shielded enclosure, with the straps at a distance no greater than 300 mm apart.	<input checked="" type="checkbox"/>	<input type="checkbox"/>	<input type="checkbox"/>
ISO11452-4, 7.2.	<ul style="list-style-type: none"> - ESA remotely grounded (vehicle power return line longer than 200 mm): two artificial networks are required, one for the positive supply line and one for the power return line)* - ESA locally grounded (vehicle power return line 200 mm or shorter): one artificial network is required, for the positive supply* <p><i>*Strikethrough, as appropriate.</i></p>			
ISO11452-4, 7.2.	Power supply is Artificial Network (AN) rated at $50 \Omega/5 \mu\text{H}$.	<input checked="" type="checkbox"/>	<input type="checkbox"/>	<input type="checkbox"/>
ISO11452-4, 7.3.	ESA and harness supported 50 ± 5 mm above ground plane, on low relative permittivity material.	<input checked="" type="checkbox"/>	<input type="checkbox"/>	<input type="checkbox"/>
ISO11452-4, 7.3.	Face of the ESA within 100 mm from the edge of the ground plane.	<input checked="" type="checkbox"/>	<input type="checkbox"/>	<input type="checkbox"/>
ISO11452-4, 7.3.	Distance of at least 500 mm between ESA and any metal parts, such as the walls of the shielded enclosure (exception is ground plane).	<input checked="" type="checkbox"/>	<input type="checkbox"/>	<input type="checkbox"/>
ISO11452-4, 7.4.	Length of test harness is $1,700 + 300$ mm, unless specified.	<input checked="" type="checkbox"/>	<input type="checkbox"/>	<input type="checkbox"/>

BCI Test Results

6.8.2.1.	No malfunction at 60 mA.	<input checked="" type="checkbox"/>	<input type="checkbox"/>	<input type="checkbox"/>
----------	--------------------------	-------------------------------------	--------------------------	--------------------------

Free Field Immunity

ISO11452-2, 8.3.1.	Test field defined by: <ul style="list-style-type: none"> - Forward power* - Another parameter, directly related* <p><i>*Strikethrough, as appropriate.</i></p>	<input checked="" type="checkbox"/>	<input type="checkbox"/>	<input type="checkbox"/>
ISO11452-2, 8.3.2.	Antenna is at a distance of $1,000 \pm 10$ mm from the reference point.	<input checked="" type="checkbox"/>	<input type="checkbox"/>	<input type="checkbox"/>
ISO11452-2, 8.3.2.	Reference point is 150 ± 10 mm above the ground plane.	<input checked="" type="checkbox"/>	<input type="checkbox"/>	<input type="checkbox"/>
ISO11452-2, 8.3.2.	Reference point is 100 ± 10 mm from the edge of the ground plane.	<input checked="" type="checkbox"/>	<input type="checkbox"/>	<input type="checkbox"/>
ISO11452-2, 8.3.2.	For frequencies from 80 - 1,000 MHz, the reference point is in the centre of the harness.	<input checked="" type="checkbox"/>	<input type="checkbox"/>	<input type="checkbox"/>
ISO11452-2, 8.3.2.	For frequencies from 1,000 - 2,000 MHz, the reference point is in line with the ESA.	<input checked="" type="checkbox"/>	<input type="checkbox"/>	<input type="checkbox"/>

Test Arrangements

ISO11452-2, 7.1.	Ground plane is made from at least 0.5 mm thick copper, brass or galvanised steel.	<input checked="" type="checkbox"/>	<input type="checkbox"/>	<input type="checkbox"/>
ISO11452-2, 7.1.	Minimum width of the ground plane is 1,000 mm and the minimum length is 2,000 mm.	<input checked="" type="checkbox"/>	<input type="checkbox"/>	<input type="checkbox"/>
ISO11452-2, 7.1.	Height of the ground plane is 900 ± 100 mm.	<input checked="" type="checkbox"/>	<input type="checkbox"/>	<input type="checkbox"/>



ISO11452-2, 7.1.	Bonding straps are at a distance no greater than 300 mm apart.	<input checked="" type="checkbox"/>	<input type="checkbox"/>	<input type="checkbox"/>
ISO11452-2, 7.2.	Power supply is Artificial Network (AN) rated at 50 Ω/5 μH.	<input checked="" type="checkbox"/>	<input type="checkbox"/>	<input type="checkbox"/>
ISO11452-2, 7.2.	<p>- ESA remotely grounded (vehicle power return line longer than 200 mm): two artificial networks are required, one for the positive supply line and one for the power return line)*</p> <p>- ESA locally grounded (vehicle power return line 200 mm or shorter): one artificial network is required, for the positive supply.*</p> <p>*Strikethrough, as appropriate.</p>			
ISO11452-2, 7.3.	AN mounted directly on the ground plane and cases bonded to the ground plane.	<input checked="" type="checkbox"/>	<input type="checkbox"/>	<input type="checkbox"/>
ISO11452-2, 7.3.	ESA and harness supported 50 ± 5 mm above table, on low relative permittivity material.	<input checked="" type="checkbox"/>	<input type="checkbox"/>	<input type="checkbox"/>
ISO11452-2, 7.3.	Face of the ESA located 200 ± 10 mm from the edge of the ground plane.	<input checked="" type="checkbox"/>	<input type="checkbox"/>	<input type="checkbox"/>
ISO11452-2, 7.4.	Test harness parallel to the front edge of the ground plane.	<input checked="" type="checkbox"/>	<input type="checkbox"/>	<input type="checkbox"/>
ISO11452-2, 7.4.	Total length of harness does not exceed 2,000 mm.	<input checked="" type="checkbox"/>	<input type="checkbox"/>	<input type="checkbox"/>
ISO11452-2, 7.4.	Actual wiring harness length: <input type="text" value="N/A"/> m	<input type="checkbox"/>	<input type="checkbox"/>	<input checked="" type="checkbox"/>
ISO11452-2, 7.4.	or Length is 1,500 ± 75 mm between ECU and AN.	<input checked="" type="checkbox"/>	<input type="checkbox"/>	<input type="checkbox"/>
ISO11452-2, 7.4.	Harness is at a distance of 100 ± 10 mm from the edge of the ground plane.	<input checked="" type="checkbox"/>	<input type="checkbox"/>	<input type="checkbox"/>
ISO11452-2, Fig 1	Front face of ESA is at least 1.0 m from all other conductive structures.	<input checked="" type="checkbox"/>	<input type="checkbox"/>	<input type="checkbox"/>
ISO11452-2, Fig 1	ESA harness is at least 2.0 m forward from the chamber wall.	<input checked="" type="checkbox"/>	<input type="checkbox"/>	<input type="checkbox"/>
Antenna Type(s) and Frequency Range(s)				
Ann 9, 4.1.2.	Antenna is vertically polarised.	<input checked="" type="checkbox"/>	<input type="checkbox"/>	<input type="checkbox"/>
ISO11452-2, 7.6.	Antenna is in the same position as the calibration.	<input checked="" type="checkbox"/>	<input type="checkbox"/>	<input type="checkbox"/>
ISO11452-2, 7.6.	Phase centre is 100 ± 10 mm above the ground plane.	<input checked="" type="checkbox"/>	<input type="checkbox"/>	<input type="checkbox"/>
ISO11452-2, 7.6.	Antenna elements are no closer than 250 mm to the floor of the facility, no closer than 0.5 m to any radio absorbent material, and no closer than 1.5 m to the wall of the facility.	<input checked="" type="checkbox"/>	<input type="checkbox"/>	<input type="checkbox"/>
ISO11452-2, 7.6.	Distance between wiring harness and antenna is 1,000 mm ± 10 mm, measured from the phase-centre of the biconical antenna, or the nearest part of the log-periodic and horn antennas.	<input checked="" type="checkbox"/>	<input type="checkbox"/>	<input type="checkbox"/>
Ann 9, 3.1.	Test signal modulation is: - AM, 1 kHz modulation, 80 % depth in 20 - 800 MHz frequency range; - PM, ton 577 μs, period 4,600 μs in 800 - 2,000 MHz frequency range.	<input checked="" type="checkbox"/>	<input type="checkbox"/>	<input type="checkbox"/>
Free Field Immunity Test Results				
6.8.2.	No malfunction at 30 V/m.	<input checked="" type="checkbox"/>	<input type="checkbox"/>	<input type="checkbox"/>
150 mm Stripline Immunity				
ISO11452-5, 5.3.1.	Stripline housed in a shielded room.	<input type="checkbox"/>	<input type="checkbox"/>	<input checked="" type="checkbox"/>



CETOC TS

CETOC Technical Service srl
Via della Bufalotta, 374,
00139 Roma

Inspection Report Nr.: CN-112-17-87-COM23-06482-IR
Manufacturer: Foshan Huazhao Electronics Co.,LTD
Type: HZ-W8010

This inspection report shall not be reproduced except in full, without written approval of the technical service.



ISP N° 0184 E

Membro degli Accordi di Mutuo Riconoscimento
EA, IAF e ILAC

Signatory of EA, IAF and ILAC
Mutual Recognition Agreements

ISO11452-5, 6.2.2. Test field defined by:

- Forward power*
 - Another parameter, directly related*
- *Strikethrough, as appropriate.

ISO11452-5, 6.2.3. Field probe in the centre of stripline.

Installation of ESA under Test

ISO11452-5, 5.3.1. ESA is 200 + 20 - 0 mm from the edge of the active conductor.

ISO11452-5, 5.3.1. Peripherals are a minimum of 200 mm from the edge of the active conductor.

ISO11452-5, 5.3.1. Harness supported 50 mm above the ground plane and is placed in the centre of the stripline.

ISO11452-5, 5.3.1. Actual wiring harness length:
or
Minimum length under stripline is 1,000 mm.

N/A m

ISO11452-5, 5.3.1. All wires in the harness are terminated or open, according to the vehicle application.

ISO11452-5, 5.3.1. Device and peripherals connected to the ground plane, as specified by the vehicle installation.

ISO11452-5, 5.3.1. Power supply is Artificial Network (AN) rated at 50 Ω/5 μH.

- ESA remotely grounded (vehicle power return line longer than 200 mm): two artificial networks are required, one for the positive supply line and one for the power return line)*
 - ~~ESA locally grounded (vehicle power return line 200 mm or shorter): one artificial network is required, for the positive supply*~~
- *Strikethrough, as appropriate.

150 mm Stripline Test Results

6.8.2. No malfunction at 50 V/m.

800 mm Stripline Immunity

Ann 9, 4.5.2.1. Stripline housed in a screened room.

Ann 9, 4.5.2.1. Stripline positioned a minimum of 2,000 mm from the walls or metallic enclosure.

Ann 9, 4.5.2.1. Stripline placed on non-conducting supports at least 400 mm above the floor.

Ann 9, 4.5.2.2. Field probe positioned within the central one-third of the longitudinal, vertical and transverse dimensions of the space between the parallel plates, with the system under test absent.

Ann 9, 4.5.2.2. Test field defined by:
- Forward power*
- Another parameter, directly related*
*Strikethrough, as appropriate.



CETOC TS

CETOC Technical Service srl
Via della Bufalotta, 374,
00139 Roma

Inspection Report Nr.: CN-112-17-87-COM23-06482-IR
Manufacturer: Foshan Huazhao Electronics Co.,LTD
Type: HZ-W8010



ISP N° 0184 E

Membro degli Accordi di Mutuo Riconoscimento
EA, IAF e ILAC

Signatory of EA, IAF and ILAC
Mutual Recognition Agreements

This inspection report shall not be reproduced except in full, without written approval of the technical service.

Installation of ESA under Test

- Ann 9, 4.5.2.3. ESA is within the central one-third of the stripline.
- Ann 9, 4.5.2.3. ESA is supported on non-conducting material.
- Ann 9, 4.5.2.4. Wiring loom is arranged as per Appendix 1, Figure 3.
- Ann 9, 4.5.2.4. Associated equipment is a minimum of 1,000 mm from stripline.

800 mm Stripline Test Results

Frequency Suggested (MHz)	Frequency (MHz)	Forward Power		Output Level		Field Strength (V/m)
		Cal. (w)	Test (w)	Cal. (dBm)	Test (dBm)	
N/A	N/A	N/A	N/A	N/A	N/A	N/A
N/A	N/A	N/A	N/A	N/A	N/A	N/A

- 6.8.2. No malfunction at 12.5 V/m.

Transient Testing

- Case of ESA is:
- ~~Grounded, simulating actual vehicle configuration*~~
- Not grounded, simulating actual vehicle configuration*
- *Strikethrough, as appropriate.

Transient Immunity

- 6.9.1. Test set up according to ISO 7637-2 (second edition 2004 and Amd.1:2008).
- Ann 10, 2. Supply lines and other lines, which may be connected to supply lines, are tested.
- Test voltage and time parameters are within allowed envelopes.
- Test pulses and duration according to the following:

Test Pulse	Immunity Test Level	Functional Status for Systems		Test Duration
		Related to Immunity-related Functions	Not Related to Immunity-related Functions	
1	III	C	D	5000 pulses
2a	III	B	D	5000 pulses
2b	III	C	D	10 pulses
3a	III	A	D	1 hour
3b	III	A	D	1 hour
4	III	B (for ESA, which must be operational during engine start, or C, for other ESA)	D	1 pulse

- ESA operational after the tests, according to the above classification.



CETOC TS

CETOC Technical Service srl
Via della Bufalotta, 374,
00139 Roma

Inspection Report Nr.: CN-112-17-87-COM23-06482-IR
Manufacturer: Foshan Huazhao Electronics Co.,LTD
Type: HZ-W8010

This inspection report shall not be reproduced except in full, without written approval of the technical service.



ISP N° 0184 E

Membro degli Accordi di Mutuo Riconoscimento
EA, IAF e ILAC

Signatory of EA, IAF and ILAC
Mutual Recognition Agreements

Emission of Conducted Disturbances

- 6.9.1. Test set up according to ISO 7637-2.
- Ann 10, 3. Supply lines and other lines, which may be connected to supply lines, are tested.
- Slow pulses and fast pulses tested on both powering up and powering down.

Polarity of Pulse Amplitude	Maximum Allowed Pulse Amplitude	
	Vehicles with 12 V systems	Vehicles with 24 V system
Positive	+ 75 V	+ 150 V
Negative	- 100 V	- 450 V

Remarks

None

Note: CETOC TS apply measurement uncertainty to calibrated items but not test results.



CETOC TS

CETOC Technical Service srl
Via della Bufalotta, 374,
00139 Roma

Inspection Report Nr.: CN-112-17-87-COM23-06482-IR
Manufacturer: Foshan Huazhao Electronics Co.,LTD
Type: HZ-W8010

This inspection report shall not be reproduced except in full, without written approval of the technical service.



ISP N° 0184 E

Membro degli Accordi di Mutuo Riconoscimento
EA, IAF e ILAC

Signatory of EA, IAF and ILAC
Mutual Recognition Agreements

APPENDIX 4 – TEST RESULTS

APPENDIX 4.1 Radiated Emissions

Vehicles with 12V systems

Horizontal Polarisation 30MHz to 1GHz

ECE R10.06(双锥-Horizontal)

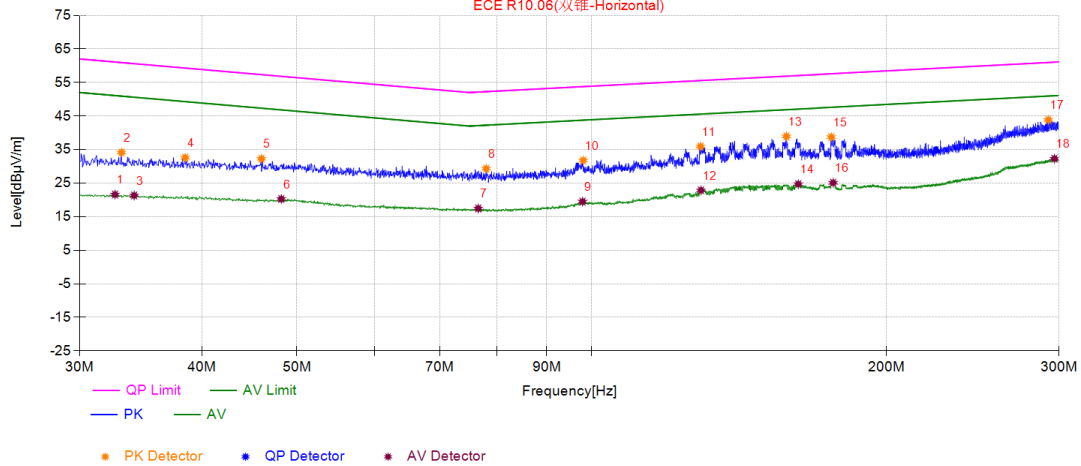

ECE R10.06(对数-Horizontal)

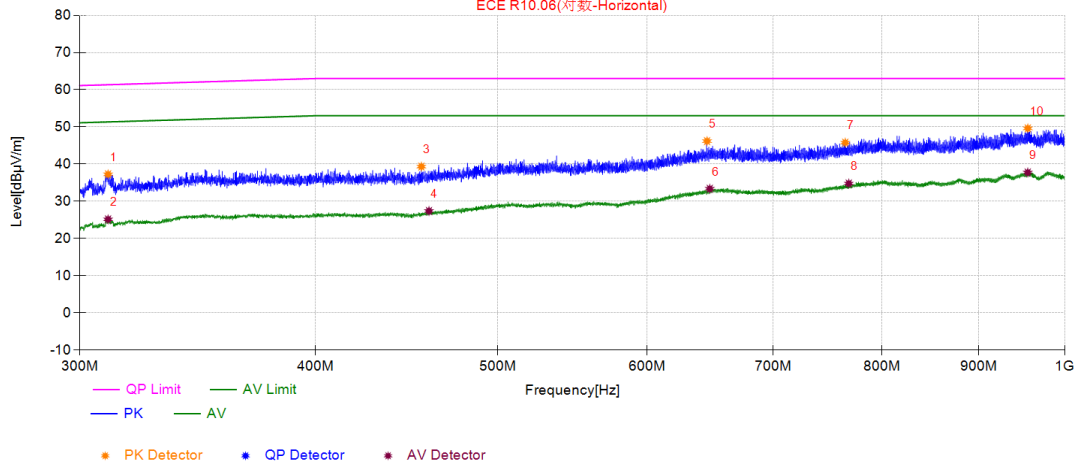



Vertical Polarisation
 30MHz to 1GHz

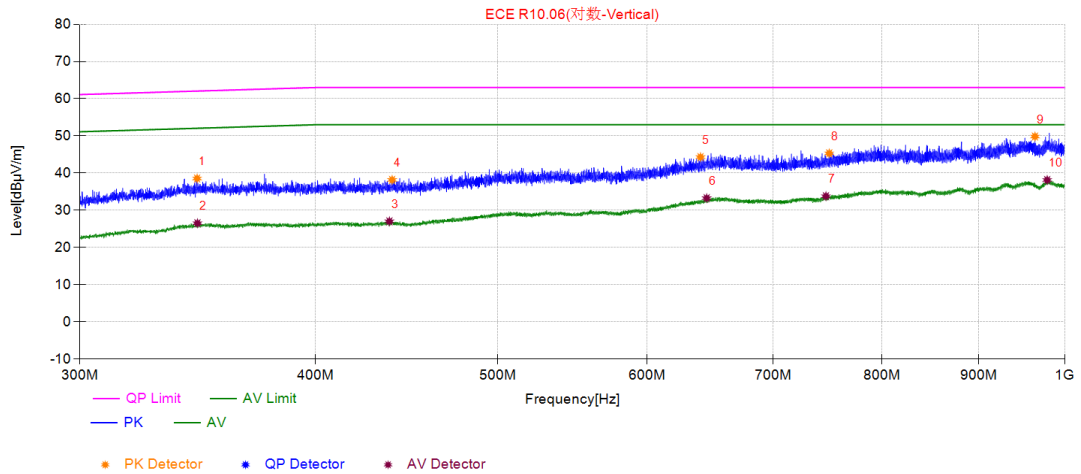
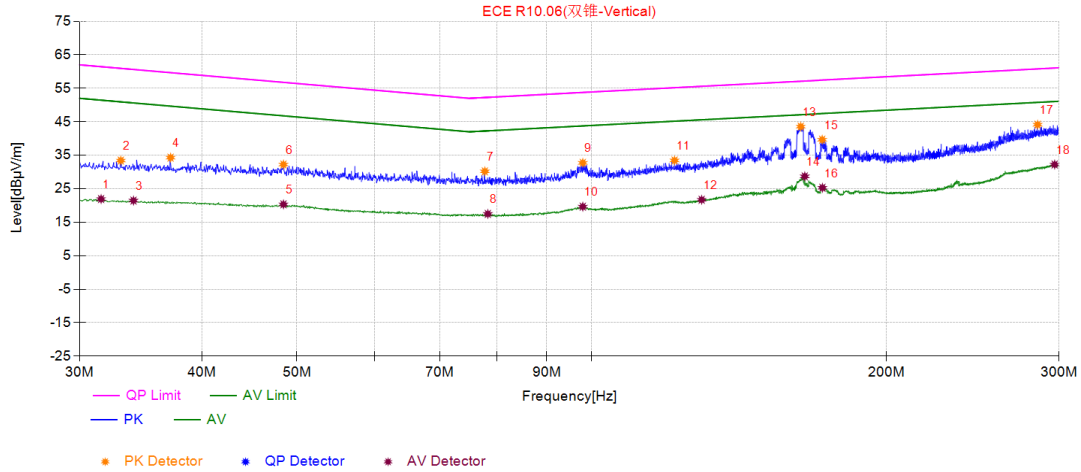



Vehicles with 24V systems

Horizontal Polarisation
 30MHz to 1GHz

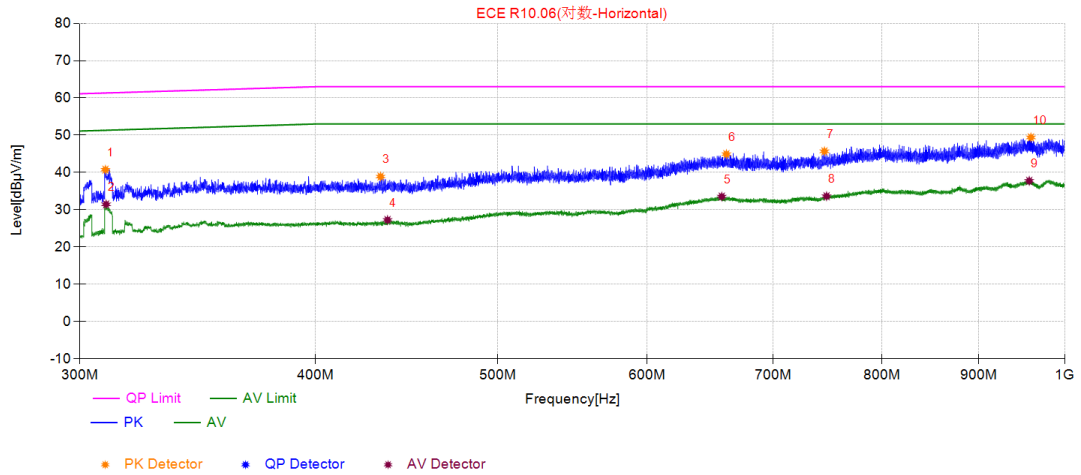
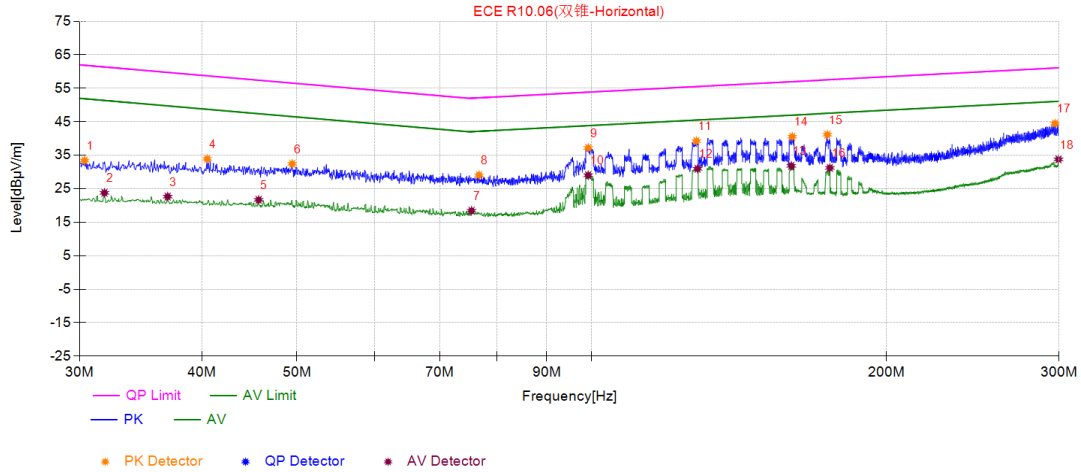



Vertical Polarisation
 30MHz to 1GHz

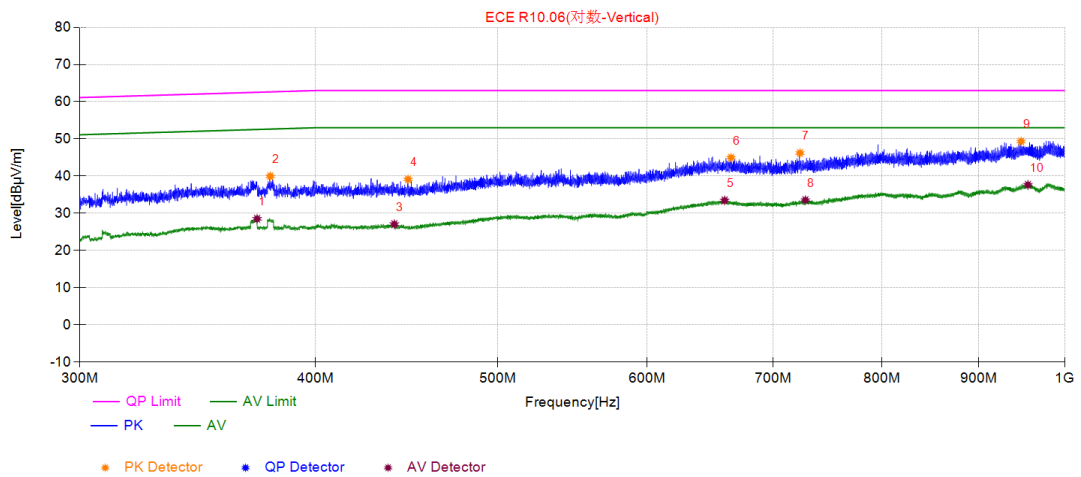
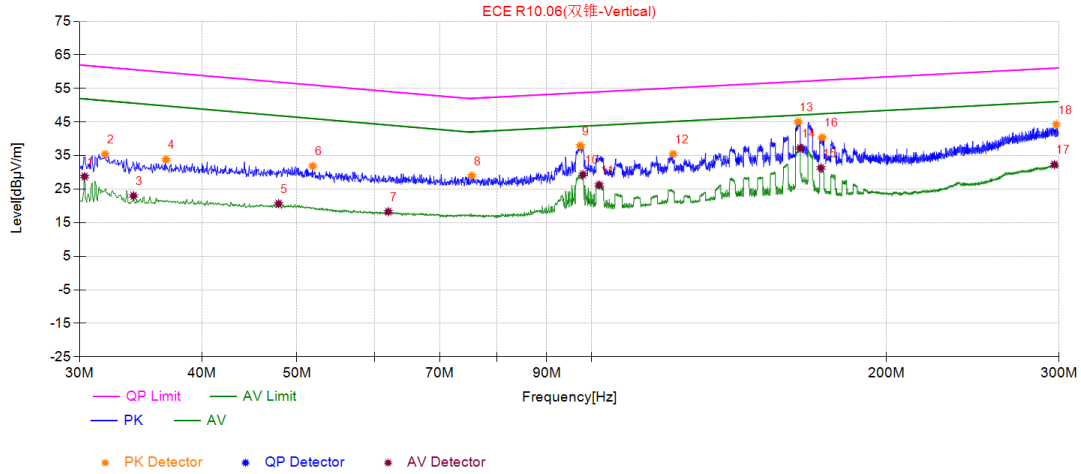



CETOC TS

CETOC Technical Service srl
Via della Bufalotta, 374,
00139 Roma

Inspection Report Nr.: CN-112-17-87-COM23-06482-IR
Manufacturer: Foshan Huazhao Electronics Co.,LTD
Type: HZ-W8010



ISP N° 0184 E

Membro degli Accordi di Mutuo Riconoscimento
EA, IAF e ILAC

Signatory of EA, IAF and ILAC
Mutual Recognition Agreements

This inspection report shall not be reproduced except in full, without written approval of the technical service.

APPENDIX 4.2 Radiated Immunity

Frequency (MHz)	Level (V/m)	Modulation	Polarity	Accept Status	Test Result	
					Vehicles with 12V systems	Vehicles with 24V systems
400-800	30	AM (1kHz,80%)	V	I	A	A
800-1000	30	PM	V	I	A	A
1000-2000	30	PM	V	I	A	A

APPENDIX 4.3 BCI Immunity

Frequency (MHz)	Level (mA)	Modulation	Injection place	Test Result	
				Vehicles with 12V systems	Vehicles with 24V systems
20-400	60	AM (1kHz,80%)	150mm	A	A

APPENDIX 4.4 Transient Immunity

Test Pulse	Immunity Test Level	Functional Status for Systems		Test results	
		Related to Immunity-related Functions	Not Related to Immunity-related Functions	Vehicles with 12V systems	Vehicles with 24V systems
1	III	C	D	C	C
2a	III	B	D	A	A
2b	III	C	D	C	C
3a	III	A	D	A	A
3b	III	A	D	A	A
4	III	C	D	B	A



APPENDIX 4.5 Emission of Conducted Disturbances

Vehicles with 12 V systems

Slow Pulse: OFF-->ON Data Graph

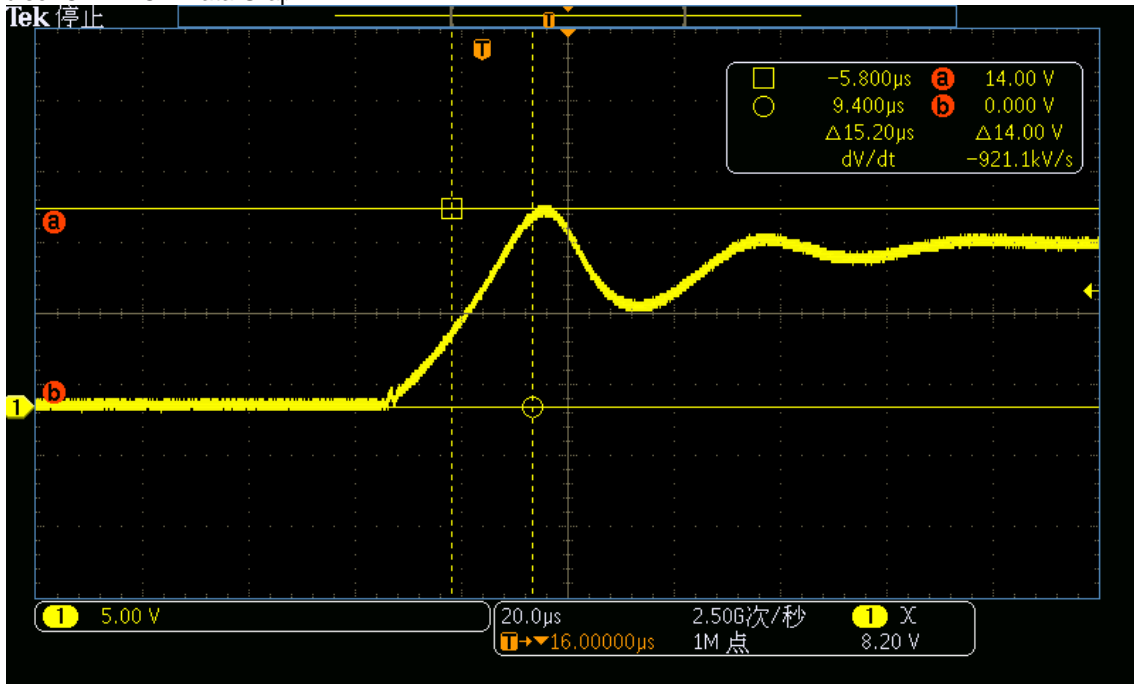

Slow Pulse: ON-->OFF Data Graph

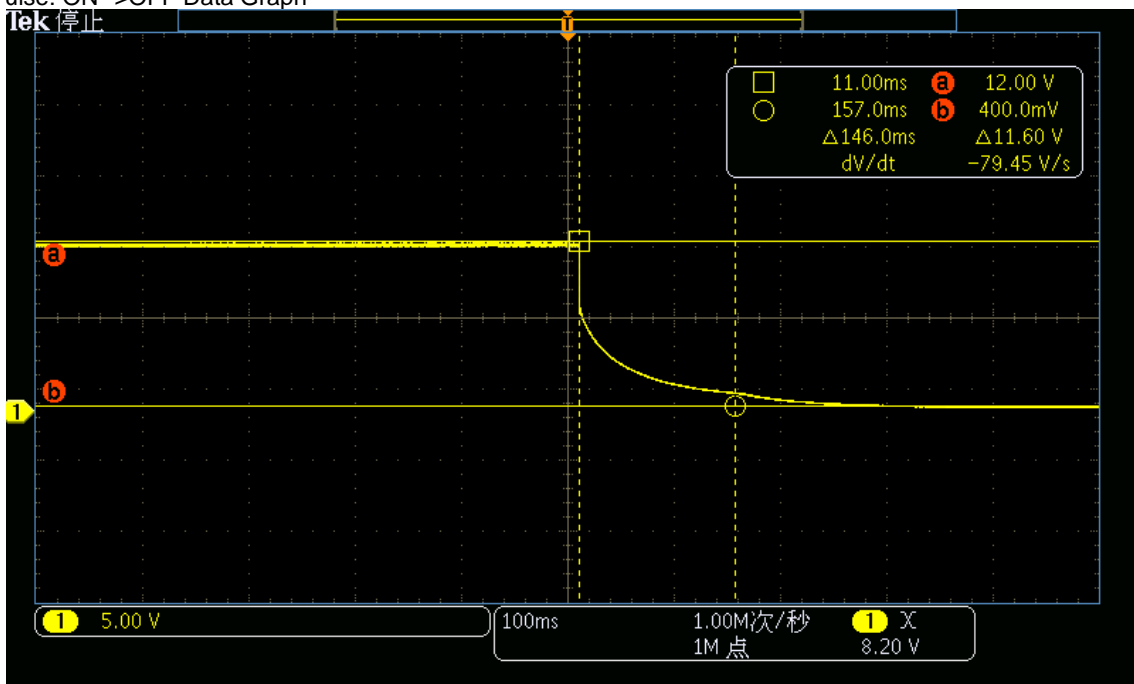



Fast Pulse: OFF-->ON Data Graph

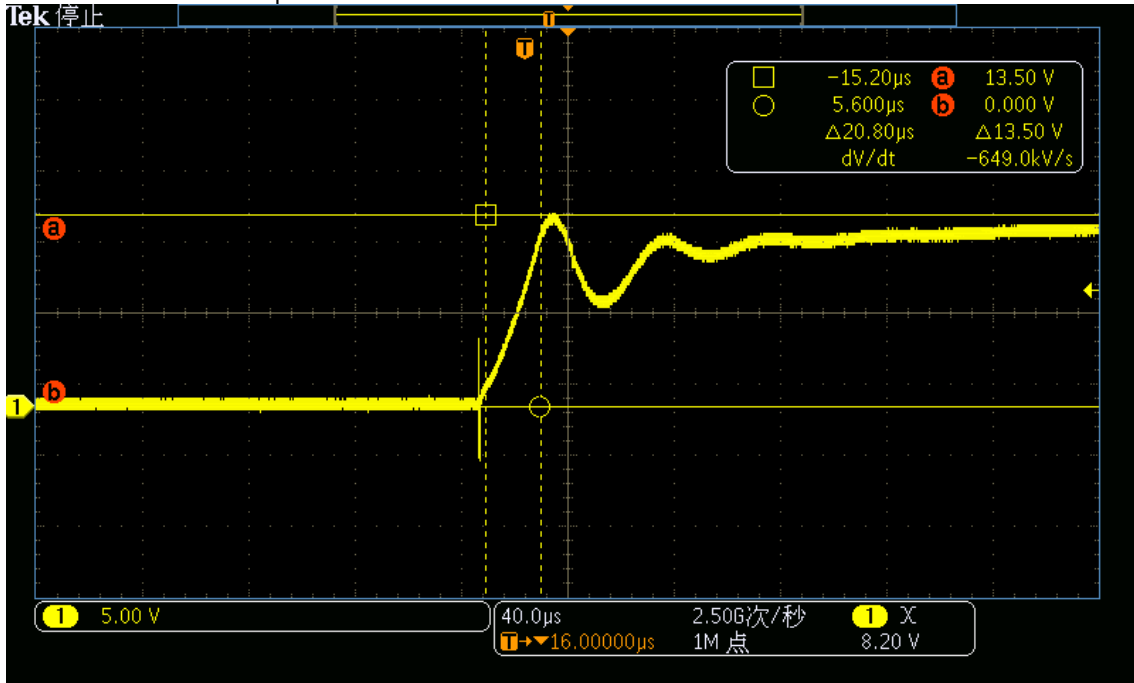

Fast Pulse: ON-->OFF Data Graph

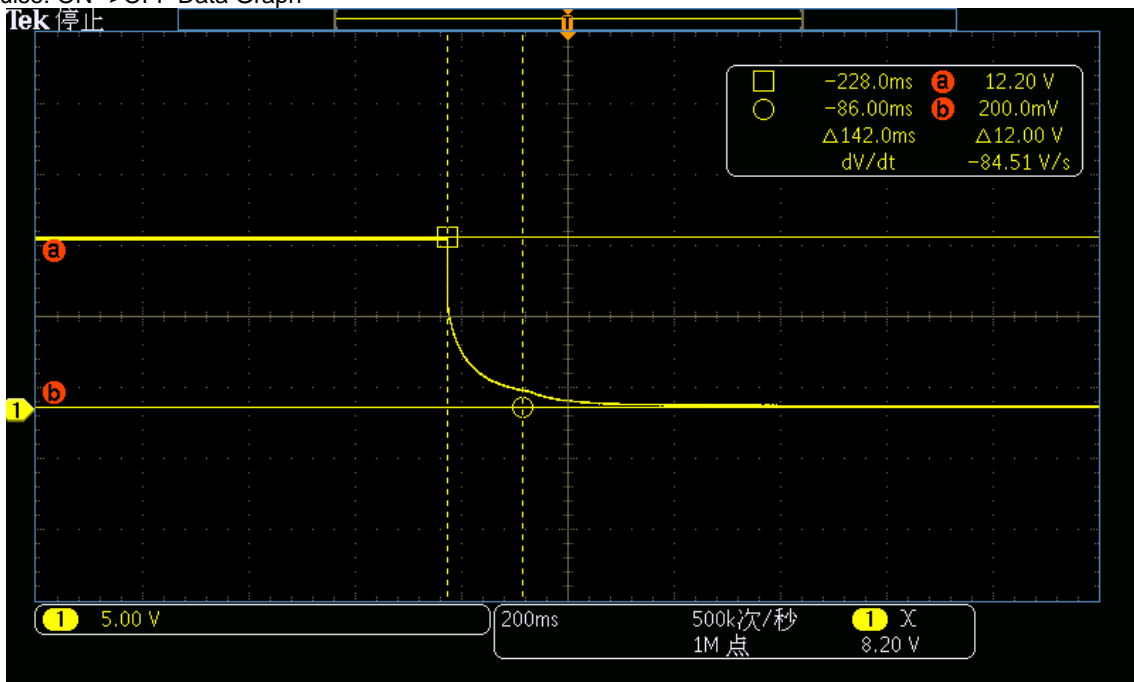



CETOC TS

CETOC Technical Service srl
Via della Bufalotta, 374,
00139 Roma

Inspection Report Nr.: CN-112-17-87-COM23-06482-IR
Manufacturer: Foshan Huazhao Electronics Co.,LTD
Type: HZ-W8010

This inspection report shall not be reproduced except in full, without written approval of the technical service.



ISP N° 0184 E

Membro degli Accordi di Mutuo Riconoscimento
EA, IAF e ILAC

Signatory of EA, IAF and ILAC
Mutual Recognition Agreements

Vehicles with 24 V systems

Slow Pulse: OFF-->ON Data Graph

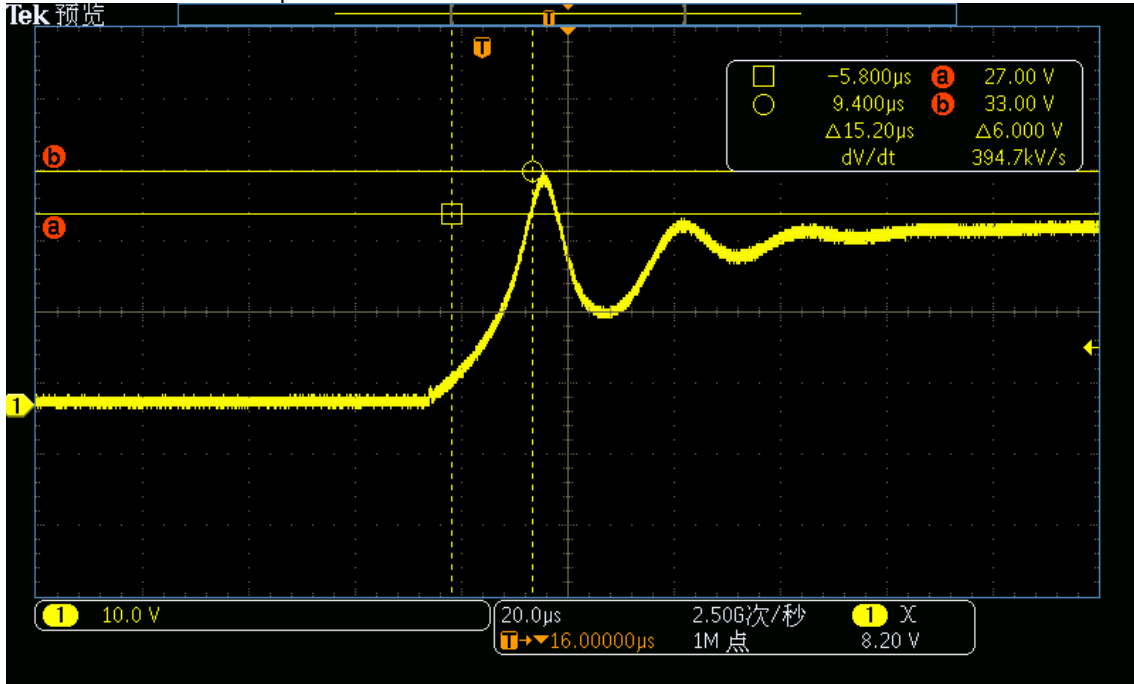

Slow Pulse: ON-->OFF Data Graph

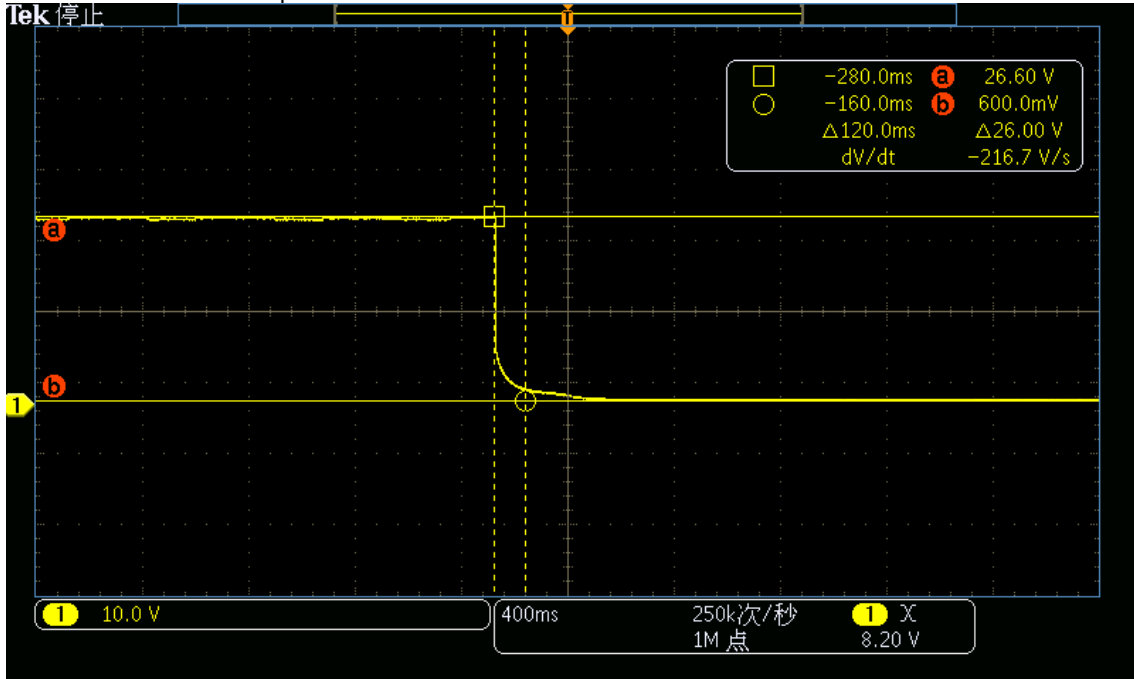



Inspection Report Nr.: CN-112-17-87-COM23-06482-IR
 Manufacturer: Foshan Huazhao Electronics Co.,LTD
 Type: HZ-W8010



ISP N° 0184 E

Membro degli Accordi di Mutuo Riconoscimento
 EA, IAF e ILAC

Signatory of EA, IAF and ILAC
 Mutual Recognition Agreements

CETOC TS

CETOC Technical Service srl
 Via della Bufalotta, 374,
 00139 Roma

This inspection report shall not be reproduced except in full, without written approval of the technical service.

Fast Pulse: OFF-->ON Data Graph

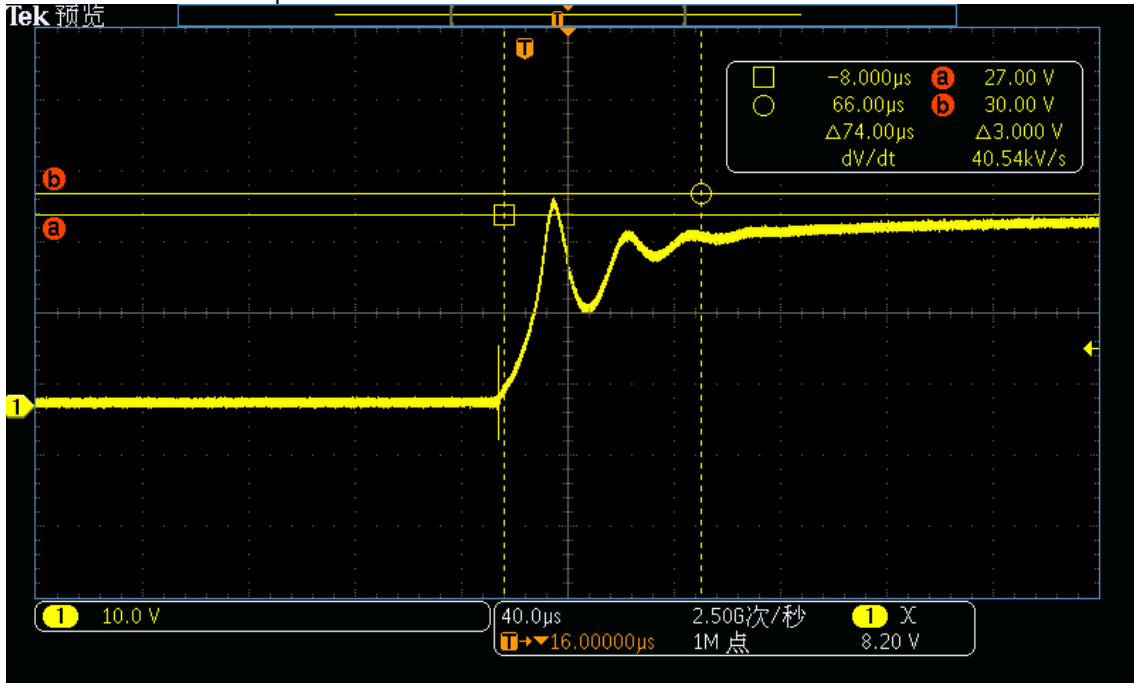

Fast Pulse: ON-->OFF Data Graph

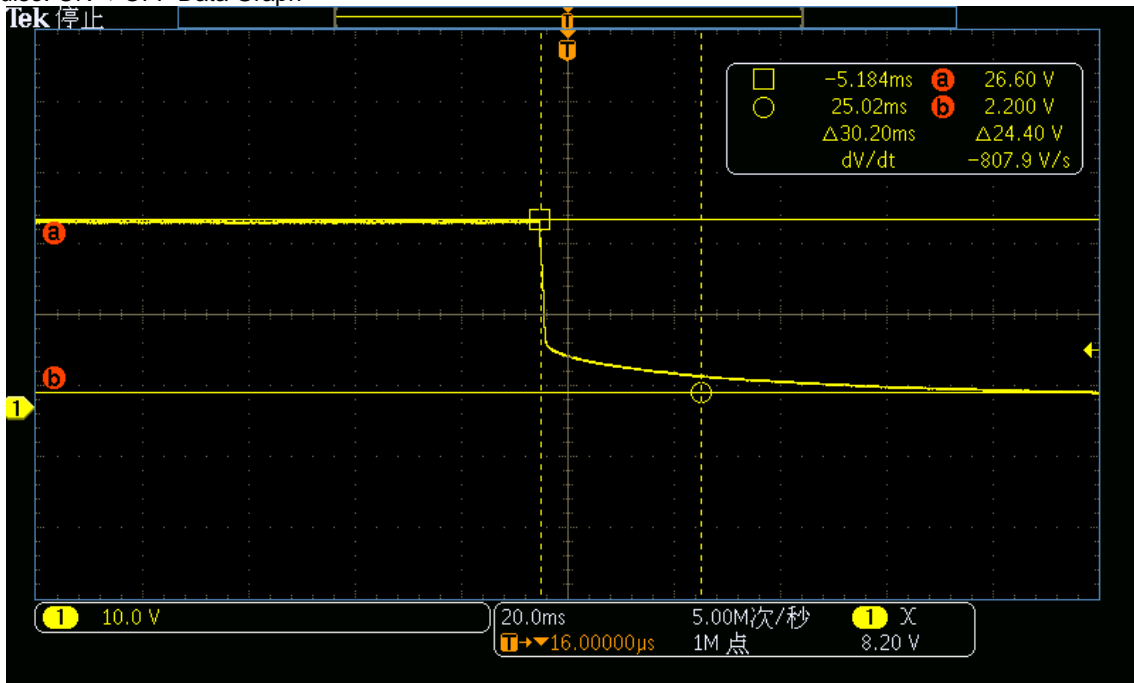

**Information document no. HZ-W8010-00 relating to type-approval of an
electronic subassembly with respect to electromagnetic compatibility (ECE
Regulation 10.06 to Supplement 2)**

Type : HZ-W8010
Date : 2023/01/31
Manufacturer : Foshan Huazhao Electronics Co.,LTD
Total pages : 7

Information folder No. : HZ-W8010-00
Manufacturer : Foshan Huazhao Electronics Co.,LTD
Regulation : R10.06 to Supplement 2

INDEX

- 2 Index
- 3 General
- 5 Drawings of the ESA
- 6 Electronic block diagram
- 7 List of components constituting the ESA

Information folder No. : HZ-W8010-00
Manufacturer : Foshan Huazhao Electronics Co.,LTD
Regulation : R10.06 to Supplement 2

GENERAL

1. Make (trade name of manufacturer):
HUAZHAO

2. Type: **HZ-W8010**
Variants:**HZ-W8012, HZ9001, HZ9002, HZ9003, HZ9004, HZ1021D, HZ1022D, HZ1031, HZ1040S, HZ7011, HZ7010, HZ9006, HZ-8011, HZ1050, HZ30128, HZ9007, HZ1040F, HZ9005, HZ1040D, HZ2098, HZ-W8010**

Above variants have the same electronic circuit design and the same component list for each PCB, the differences among them are the light Appearance and size.

General commercial description(s):
LED LAMP LIGHT

3. Means of identification of type, if marked on the component/separate technical unit ⁽¹⁾:
Approval mark

- 3.1 Location of that marking:
Marked on Lens, See Drawings of the ESA

4. Name and address of manufacturer:
**Foshan Huazhao Electronics Co.,LTD
6th floor, C Building, No. 1 Xinfeng Road.Songgang Songxia Industrial Park, Shishan Town, Nanhai District, FoshanCity/528225, Guangdong Province, China**
Name and address of authorised representative, if any:**N/A**

5. In the case of components and separate technical units, location and method of affixing of the approval mark:
Marked on Lens, See Drawings of the ESA

6. Address(es) of assembly plant(s):
**Foshan Huazhao Electronics Co.,LTD
6th floor, C Building, No. 1 Xinfeng Road.Songgang Songxia Industrial Park, Shishan Town, Nanhai District, FoshanCity/528225, Guangdong Province, China**

7. This ESA shall be approved as a component/STU².

8. Any restrictions of use and conditions for fitting:
N/A

9. Electrical system rated voltage:
DC 12/24V, positive/negative² ground.

Appendix 1: Description of the ESA chosen to represent the type (electronic block diagram and list of main component constituting the ESA (e.g. make and type of microprocessor, crystal, etc.).

See electronic block diagram and list of main component constituting the ESA for details.

Appendix 2: Relevant test report(s) supplied by the manufacturer from a test laboratory accredited to ISO 17025 and recognized by the Type Approval Authority for the purpose of drawing up the type approval certificate.

N/A

Only applicable for charging systems: **N/A**

10. Charger:
N/A
11. Charging current:
N/A
12. Maximal nominal current (in each mode if necessary) :
N/A
13. Nominal charging voltage:
N/A
14. Basic ESA interface functions:
N/A
15. Minimum $R_{s_{ce}}$ value (see paragraph 7.11. of this Regulation):
N/A

1. If the means of identification of type contains characters not relevant to describe the component or separate technical unit types covered by this information document, such characters shall be represented in the documentation by the symbol "?" (e.g. ABC??123??).

2. Delete where not applicable.

Drawings of the ESA

Location of the ECE approval mark

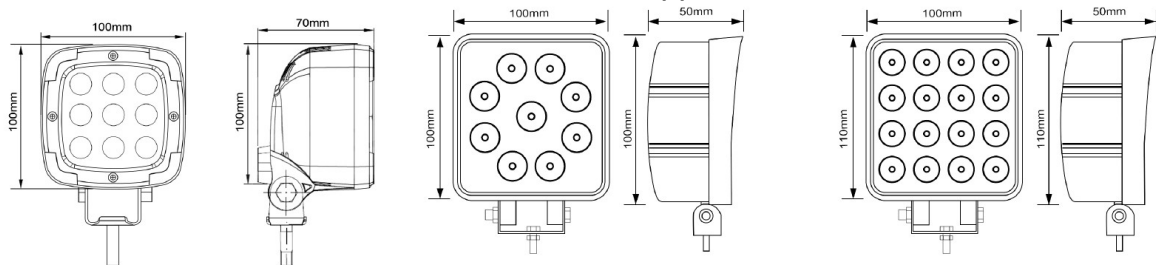

HZ-W8012

HZ9001、HZ 9002、HZ9003、HZ9004

HZ1021D、HZ1022D、HZ1031、HZ1040S

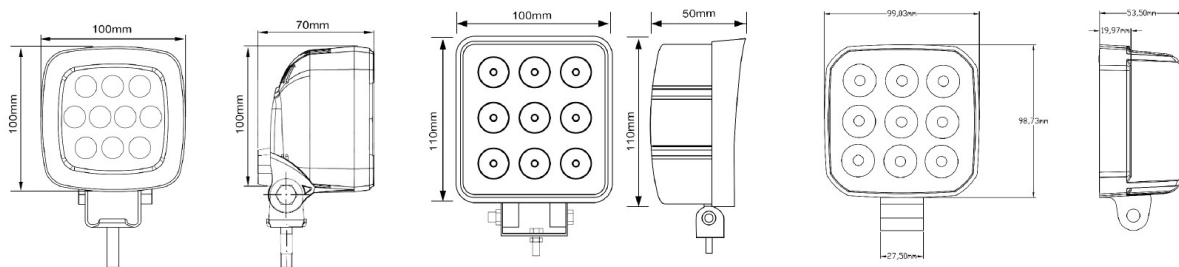

HZ7011、HZ7010

HZ9006

HZ-W8011

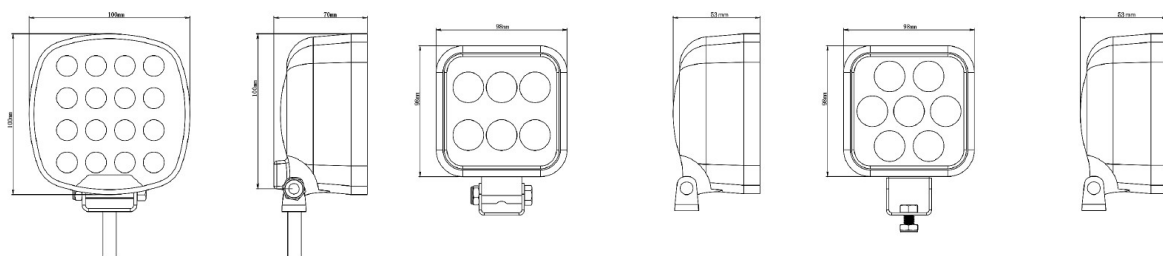

HZ1050

HZ30128

HZ9007

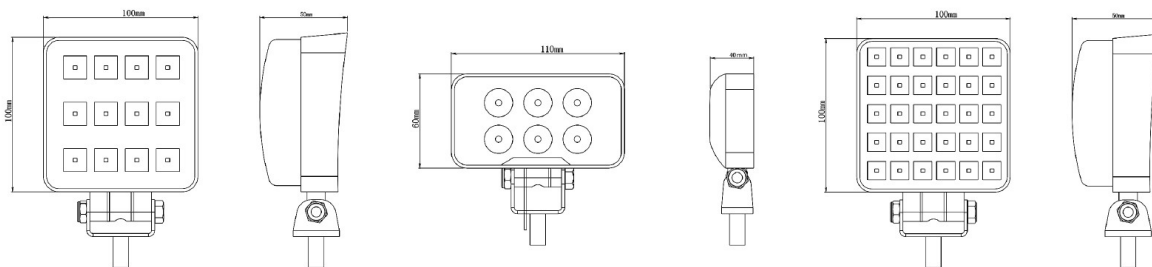

HZ1040F

HZ9005

HZ1040D

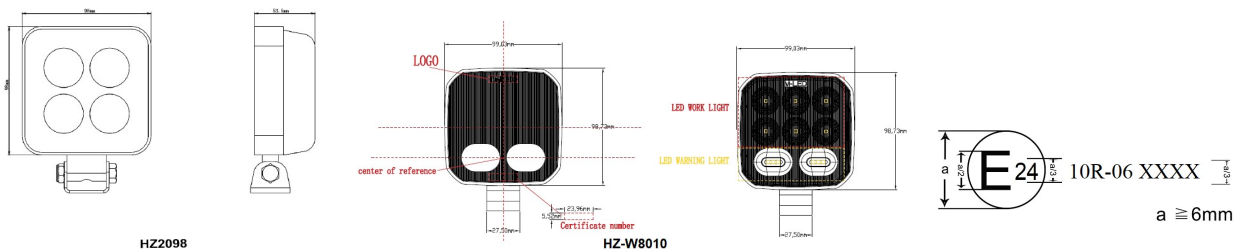

HZ2098

HZ-W8010

Electronic Block Diagram

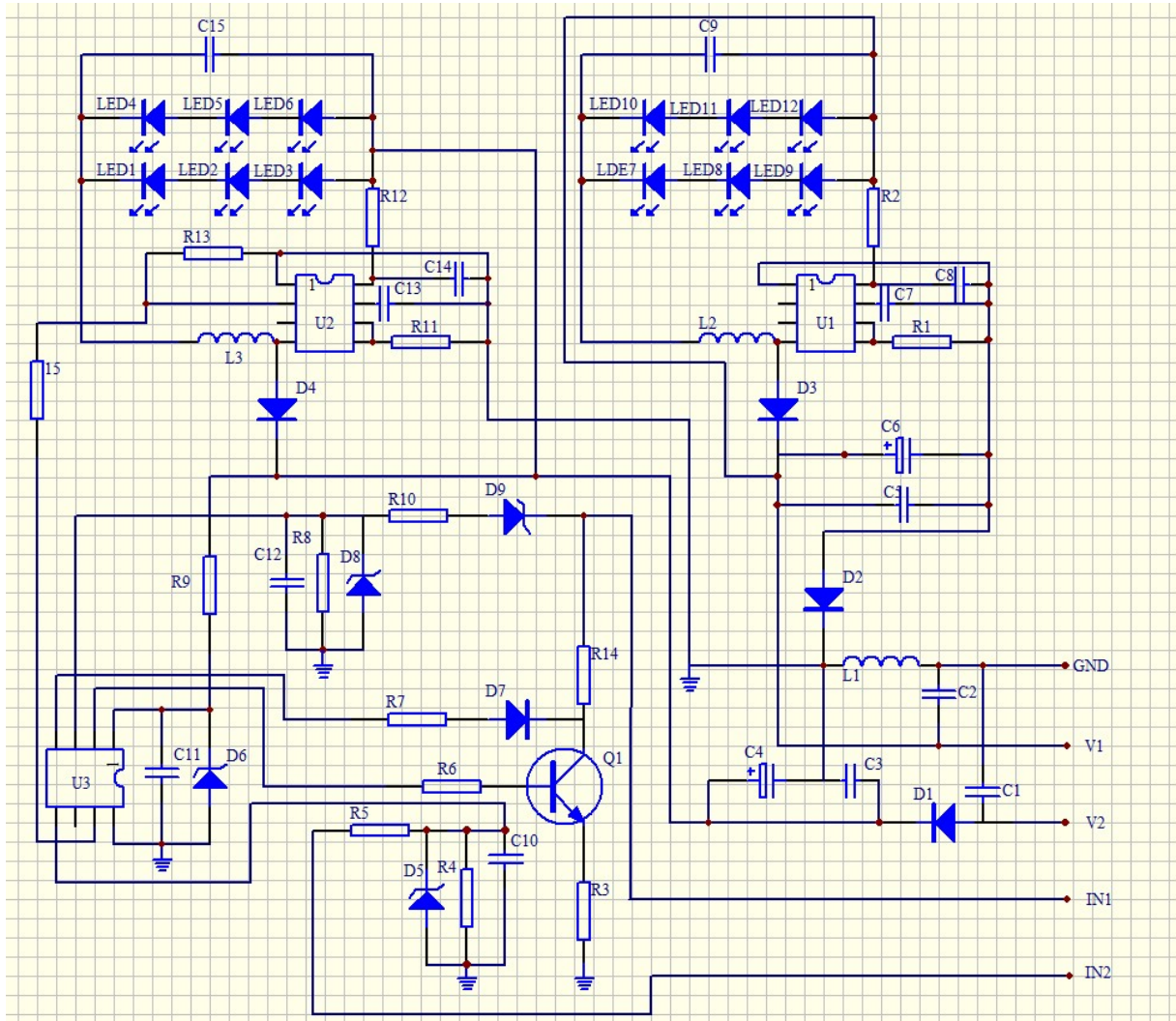

Information folder No. : HZ-W8010-00
Manufacturer : Foshan Huazhao Electronics Co.,LTD
Regulation : R10.06 to Supplement 2

List of main component constituting the ESA

Name	Specification	Qty.
inductancia	0503(33UH)	3
IC	FT60F21X	1
IC	QC5022B	2
Condensadores electrolíticos	35V/47UF	2
Condensadores	35V/106	5
LED	2525 3W	12