



MINISTERIO
DE INDUSTRIA, COMERCIO Y
TURISMO

DIRECCIÓN GENERAL DE INDUSTRIA Y
DE LA PEQUEÑA Y MEDIANA EMPRESA

SUBDIRECCIÓN GENERAL DE
CALIDAD Y SEGURIDAD INDUSTRIAL



E9*65R00/10*6235*00 REV. 01

Página /Page 1/2

**REVISIONES ACEPTADAS EN EL EXPEDIENTE DE HOMOLOGACIÓN /
REVISIONS APPROVED FOR THE HOMOLOGATION**

E9*65R00/10*6235*00

REV. 01

A la vista de lo expuesto en el informe nº /
Regarding the test report No : CN18120853

Del servicio técnico /
Of the technical service : IDIADA

En lo que se refiere a la homologación cuya contraseña es /
Concerning the homologation under approval number : E9*65R00/10*6235*00

Fecha / *Date* : 26/12/2018

Concedida al dispositivo / *Granted to Device:*

Marca / *Make* : NICAR

Tipo / *Type* : WL431SK

Fabricante / *Manufacturer* : ZHONGSHAN JUCAR AUTO ACCESSORIES CO., LTD.
(UNIT 701, 402 ROOM, 401 ROOM, HONGJI
INDUSTRIAL 1 PERIOD 1 BUILDING 3/F) NO. 23,
TONGJI WEST ROAD, NANTOU TOWN, 528427,
ZHONGSHAN CITY, GUANGDONG, (CHINA)

(¹) Táchese lo que no proceda / *Strike out what does not apply*



MINISTERIO
DE INDUSTRIA, COMERCIO Y
TURISMO

DIRECCIÓN GENERAL DE INDUSTRIA Y
DE LA PEQUEÑA Y MEDIANA EMPRESA

SUBDIRECCIÓN GENERAL DE
CALIDAD Y SEGURIDAD INDUSTRIAL



E9*65R00/10*6235*00 REV. 01

Página /Page 2/2

Esta Subdirección acepta para su ~~inclusión~~/sustitución ⁽¹⁾ en el correspondiente expediente de homologación, la siguiente documentación / *This Subdirection accepts the following documentation for ~~inclusión~~/replacement⁽¹⁾ in the homologation package:*

- a) Comunicación / *Communication*: Sin cambios / *No changes*
- b) Informe de ensayo / *Test report*: Sin cambios / *No changes*
- c) Documentación técnica / *Technical documentation*: (página 2/6, 3/6, 4/6, 5/6 / *page 2/6, 3/6, 4/6, 5/6*)

Donde ponía / *Where written*:

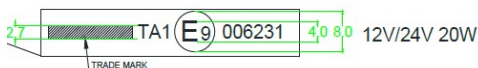

Ahora pone / *Now it is written*:

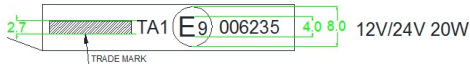

Lugar / *Place*: Madrid

Fecha / *Date*: Ver firma electrónica / *See electronic signature*

Firma / *Signature*:

EL SUBDIRECTOR GENERAL DE CALIDAD Y SEGURIDAD INDUSTRIAL
Resolución P.D. del DIRECTOR GENERAL DE INDUSTRIA Y DE LA PYME de 25-10-2012

(1) Táchese lo que no proceda / *Strike out what does not apply*

**INFORME N° / REPORT No.: CN18120853**

RELATIVO A LA HOMOLOGACIÓN DE LUCES ESPECIALES DE AVISO PARA AUTOMÓVILES SEGÚN
EL REGLAMENTO ECE 65.00 / *CONCERNING THE APPROVAL OF SPECIAL WARNING LIGHTS FOR
MOTOR VEHICLES ACCORDING TO REGULATION ECE 65.00*

REV. 01

Nombre y dirección del fabricante /
Manufacturer's name and address

: ZHONGSHAN JUCAR AUTO ACCESSORIES CO., LTD.
(UNIT 701, 402 ROOM, 401 ROOM, HONGJI INDUSTRIAL 1
PERIOD 1 BUILDING 3/F) NO. 23, TONGJI WEST ROAD,
NANTOU TOWN, 528427, ZHONGSHAN CITY,
GUANGDONG, (CHINA)

Marca comercial / *Trade mark*

: NICAR

Tipo / *Type*

: WL431SK

Lugar y fecha de emisión del informe /
Place and date of test report issue

: L'Albornar, Santa Oliva (Tarragona)
26/12/2018

CONCLUSIONES / *CONCLUSIONS*: Analizado el motivo de la modificación que se detalla en el Anexo a este informe, el dispositivo presentado **CUMPLE** las prescripciones relativas a la homologación de luces especiales de aviso para automóviles en aplicación del Reglamento N° 65.00 ECE, y se acepta para su sustitución en el expediente N° CN18110228. / *Taking into account the reason of the modification as detailed in the Annex attached to this report, this device **FULFILLS** the prescriptions with regard to the approval of special warning lights in application of Regulation No.65.00 ECE, and it accepts for replacement in the report N° CN18110228.*

Realizado/ *Performed by:*

V. B°./ *Revised by:*

Joan Fonts Sala
INGENIERO DE ENSAYOS
TEST ENGINEER

Lluís Sans Gomis
JEFE DE DEPARTAMENTO
DEPARTMENT MANAGER

* LOS RESULTADOS PRESENTADOS SE REFIEREN ÚNICAMENTE A LA MUESTRA ENSAYADA.
THE PRESENTED RESULTS REFER ONLY TO THE TESTED SAMPLE

* QUEDA TERMINANTEMENTE PROHIBIDA LA REPRODUCCION PARCIAL DE ESTE INFORME SIN PERMISO EXPRESO DE IDIADA.
THE PARTIAL REPRODUCTION OF THIS REPORT WITHOUT THE PERMISSION OF IDIADA IS COMPLETELY FORBIDDEN



ANEXO AL INFORME

ANNEX TO THE REPORT

Se acepta para su sustitución en el correspondiente expediente de homologación N° CN18110228, la siguiente información / *It accepts the following information for replacement in the homologation information package N° CN18110228.*

- a) Comunicación / *Communication*: Sin cambios / *No changes*
- b) Informe de ensayo / *Test report*: Sin cambios / *No changes*
- c) Documentación técnica / *Technical documentation*: (página 2/6, 3/6, 4/6, 5/6 / *page 2/6, 3/6, 4/6, 5/6*)

Donde ponía / *Where written*:

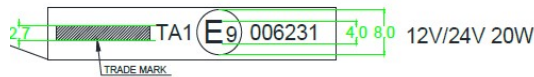

Ahora pone / *Now it is written*:

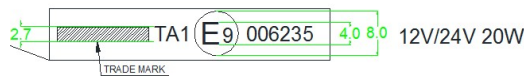

Lugar / *Place*: L'Albornar, Santa Oliva (Tarragona)

Fecha / *Date*: 26/12/2018

Joan Fonts Sala
INGENIERO DE ENSAYOS
TEST ENGINEER

* LOS RESULTADOS PRESENTADOS SE REFIEREN UNICAMENTE A LA MUESTRA ENSAYADA.
THE PRESENTED RESULTS REFER ONLY TO THE TESTED SAMPLE

* QUEDA TERMINANTEMENTE PROHIBIDA LA REPRODUCCION PARCIAL DE ESTE INFORME SIN PERMISO EXPRESO DE IDIADA.
THE PARTIAL REPRODUCTION OF THIS REPORT WITHOUT THE PERMISSION OF IDIADA IS COMPLETELY FORBIDDEN

DOCUMENTACIÓN TÉCNICA /
TECHNICAL DOCUMENTATION

First application date : November 14, 2018
 Extension date : December 26, 2018
 Reason for revision : Correction of approval marking on the drawing

1. Specification data

Type	WL431SK	
Variants	WL400SK, WL401SK, WL430SK, WL431SK	
Trade name or mark	NICAR	
Function	Warning lamp	
Applicable Regulation	ECE R65.00, Category TA1	
Nature of the beam	rotating or stationary flashing	
Flash Patterns	Two pulse per flash	
Color	AMBER	
Number and category of light sources	45xLEDs, Non-replaceable light source	
Rated	Voltage	12V/24V
	Wattage	20W (Peak) / 7W (Average)
Location of marking	Rated (V and W)	Marked on Lens
	Trade mark	Marked on Lens
	Approval mark	Marked on Lens
Number of separate units (if applicable)	Not Applicable	
Only for Class 2 lamps: System used to obtain increased intensity at daytime	Not Applicable	

2. Construction and material

Construction	Material	Remarks
Outer Lens	PC	Color: AMBER
Reflector	PC	Aluminum vapor coating
Housing	PPA/Silicone/ABS/PP/Rubber	---
Electrical wiring	Copper covered with insulation	---

3. Name and address of manufacturer : ZHONGSHAN JUCAR AUTO ACCESSORIES CO., LTD.
 (UNIT 701, 402 ROOM, 401 ROOM, HONGJI INDUSTRIAL 1 PERIOD 1 BUILDING 3/F) NO. 23, TONGJI WEST ROAD, NANTOU TOWN, 528427, ZHONGSHAN CITY, GUANGDONG, (CHINA)

4. Name and address of applicant : Not applicable

NOTE: APPROVAL MARKINGS ARE SHOWN IN THE ATTACHED DRAWING.
 THIS INFORMATION FOLDER CONSISTS OF 6 PAGES.

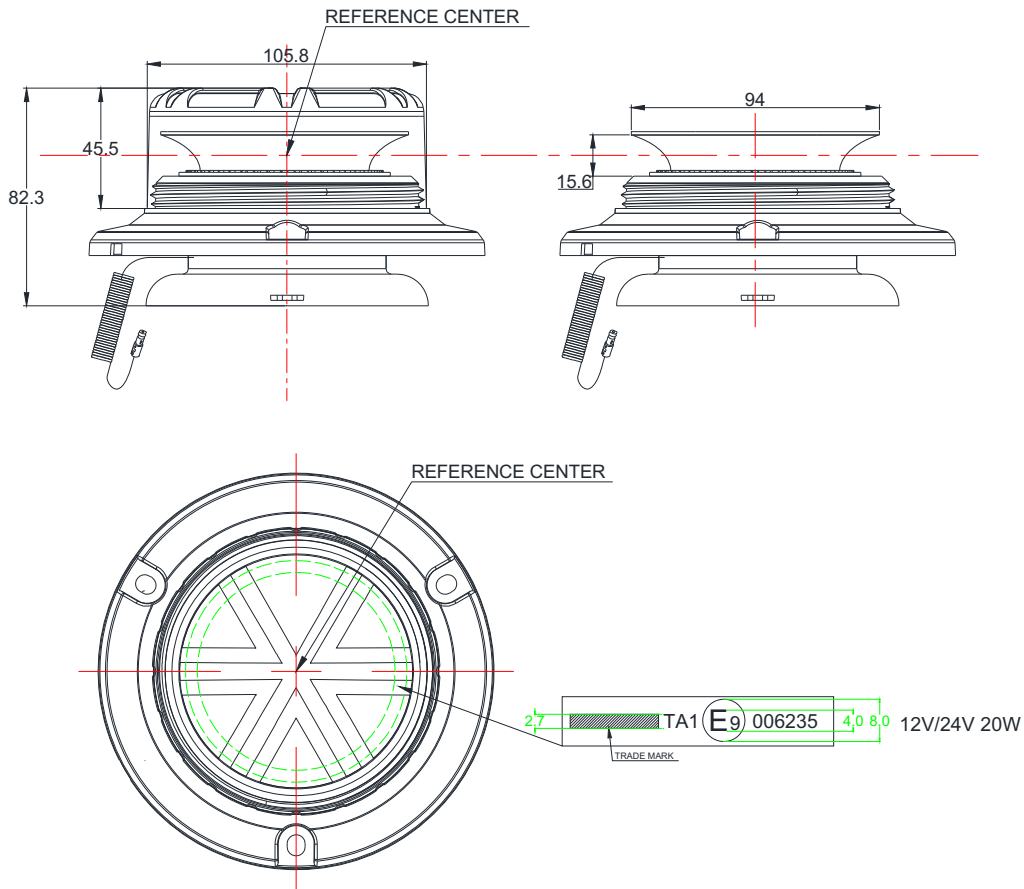

WL400SK

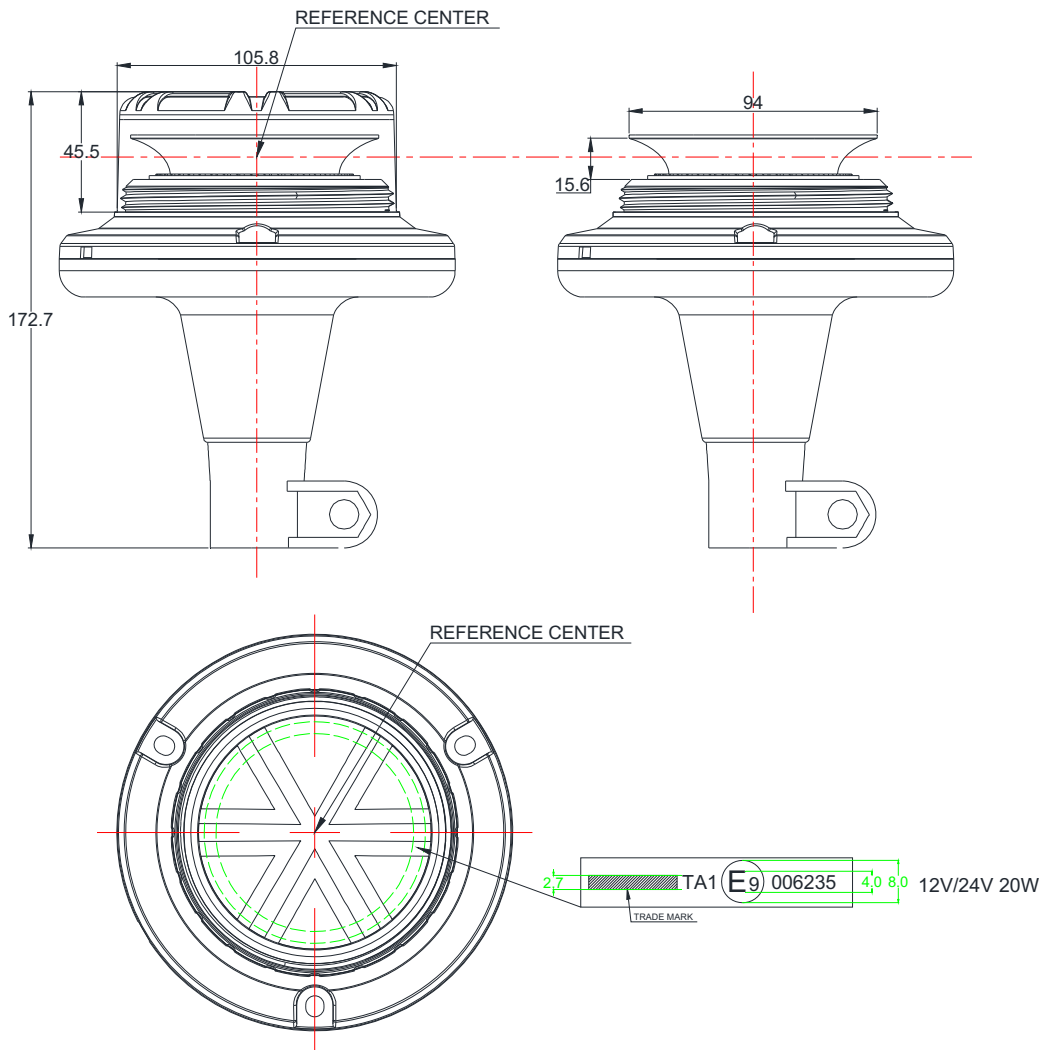

WL401SK

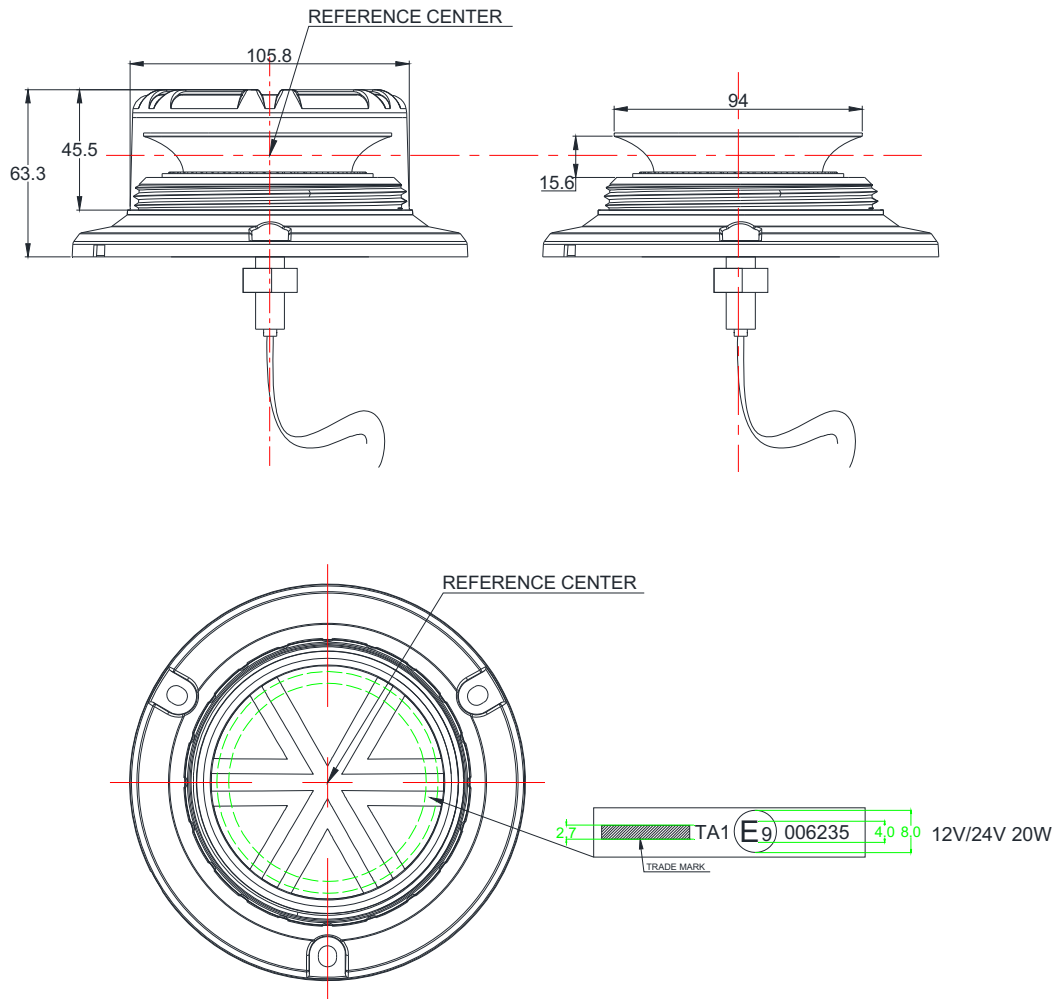

WL430SK

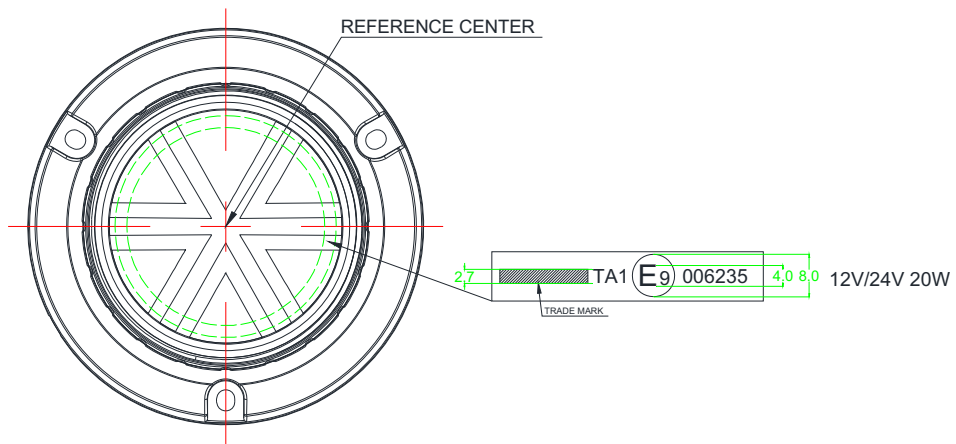
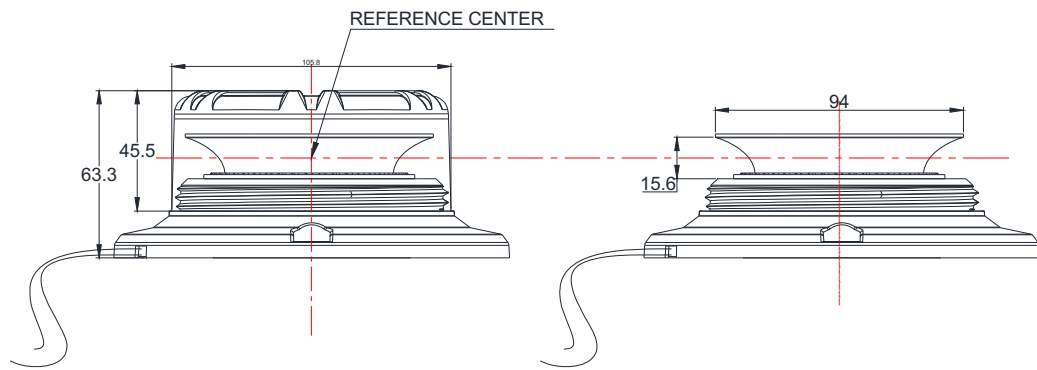

WL431SK

CIRCUIT DIAGRAM

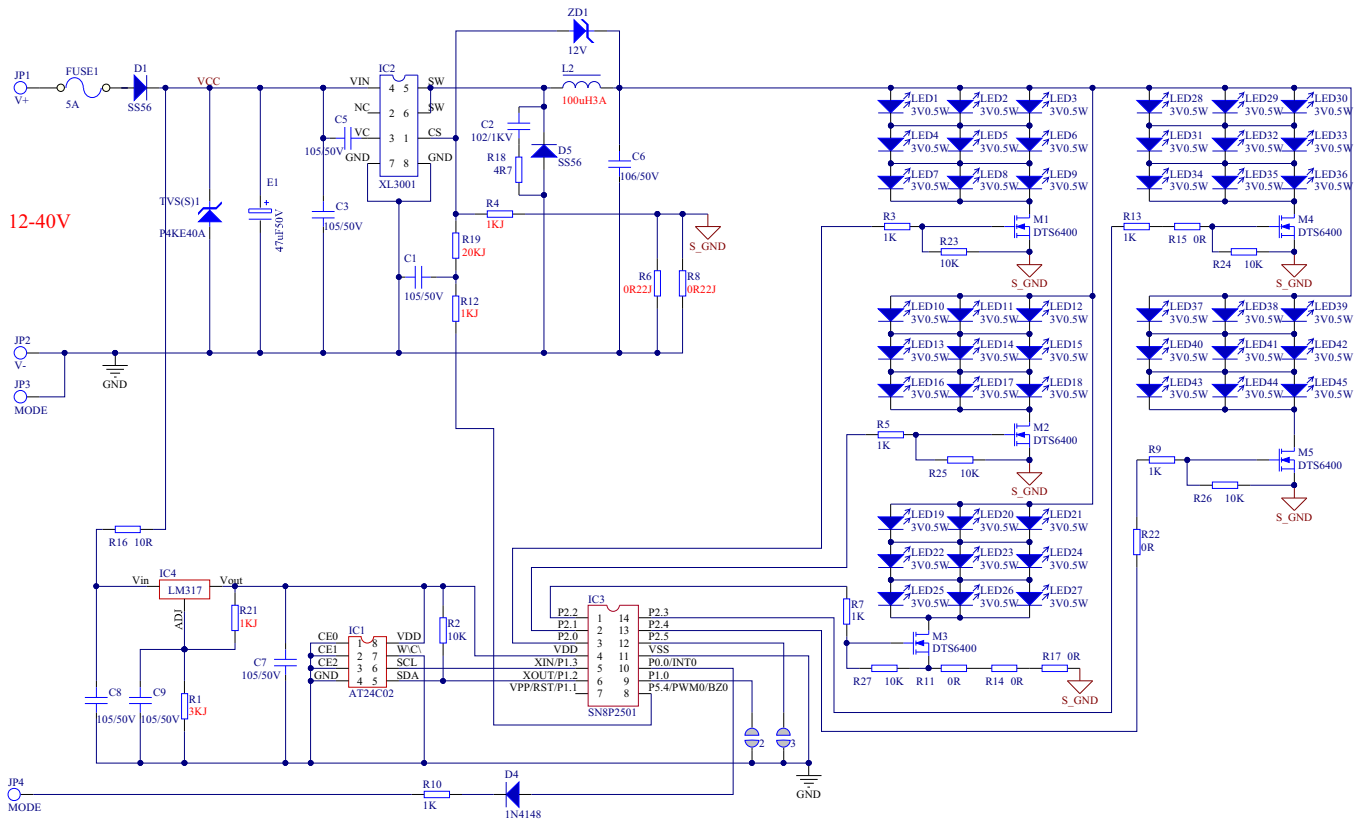

45 x LEDs, Non-replaceable light source
 12V/24V 20W (Peak) / 7W (Average)