

## **r.LiNK Video-inserter RL2-DVD900**

**Compatible with Opel, Chevrolet and Buick  
with CD500, DVD600, DVD800, DVD900,  
CD600intelliLink and DVD950intelliLink infotainment**



examples

**Video-inserter for rear-view camera  
and two additional video sources**

### **Product features**

- **Video-inserter for factory-infotainment systems**
- **2 CVBS video-inputs for after-market devices (e.g. DVD-Player, DVB-T tuner)**
- **FBAS Rear-view camera video-input**
- **Automatic switching to rear-view camera input on engagement of the reverse gear**
- **Activatable parking guide lines for rear-view camera (not available on all vehicles)**
- **Video-in-motion in drive mode (ONLY for connected video-sources)**
- **Video-inputs NTSC compatible**

## Contents

### 1. Prior to installation

- 1.1. Delivery contents
- 1.2. Checking the compatibility of vehicle and accessories
- 1.3. Boxes and connectors
  - 1.3.1. Video-Interface
  - 1.3.2. CAN box
- 1.4. Dip-switch settings of the video interface
  - 1.4.1. Enabling the interface's video inputs (dip 2-3)
  - 1.4.2. Rear-view camera setting (dip 5)
  - 1.4.3. Monitor selection (dips 6-8)

### 2. Installation

- 2.1. Place of installation
- 2.2. Connection schema
- 2.3. Connection video-interface and CAN box
- 2.4. Connection CAN box - Quadlock
- 2.5. Connection to the factory monitor
- 2.6. Connection video sources
  - 2.6.1. After-market rear-view camera
    - 2.6.1.1. Case 1: CAN box receives the reverse gear signal
    - 2.6.1.2. Case 2: CAN box does not receive the reverse gear signal (e.g. Zafira 2017)
    - 2.6.1.3. Video signal connection of rear-view camera
  - 2.6.2. Connection video source 1 and video source 2
  - 2.6.3. Audio-insertion
- 2.7. Connecting video-interface and keypad
- 2.8. Picture settings and guide lines

### 3. Interface operation

- 3.1. By "hang up" key
- 3.2. By keypad

### 4. Specifications

### 5. FAQ – Trouble shooting Interface functions

### 6. Technical support

## Legal Information

By law, watching moving pictures while driving is prohibited, the driver must not be distracted. We do not accept any liability for material damage or personal injury resulting, directly or indirectly, from installation or operation of this product. This product should only be used while standing or to display fixed menus or rear-view-camera video when the vehicle is moving, for example the MP3 menu for DVD upgrades.

Changes/updates of the vehicle's software can cause malfunctions of the interface. We offer free software-updates for our interfaces for one year after purchase. To receive a free update, the interface must be sent in at own cost. Labor cost for and other expenses involved with the software-updates will not be refunded.

## 1. Prior to installation

Read the manual prior to installation.

Technical knowledge is necessary for installation. The place of installation must be free of moisture and away from heat sources.

### 1.1. Delivery contents

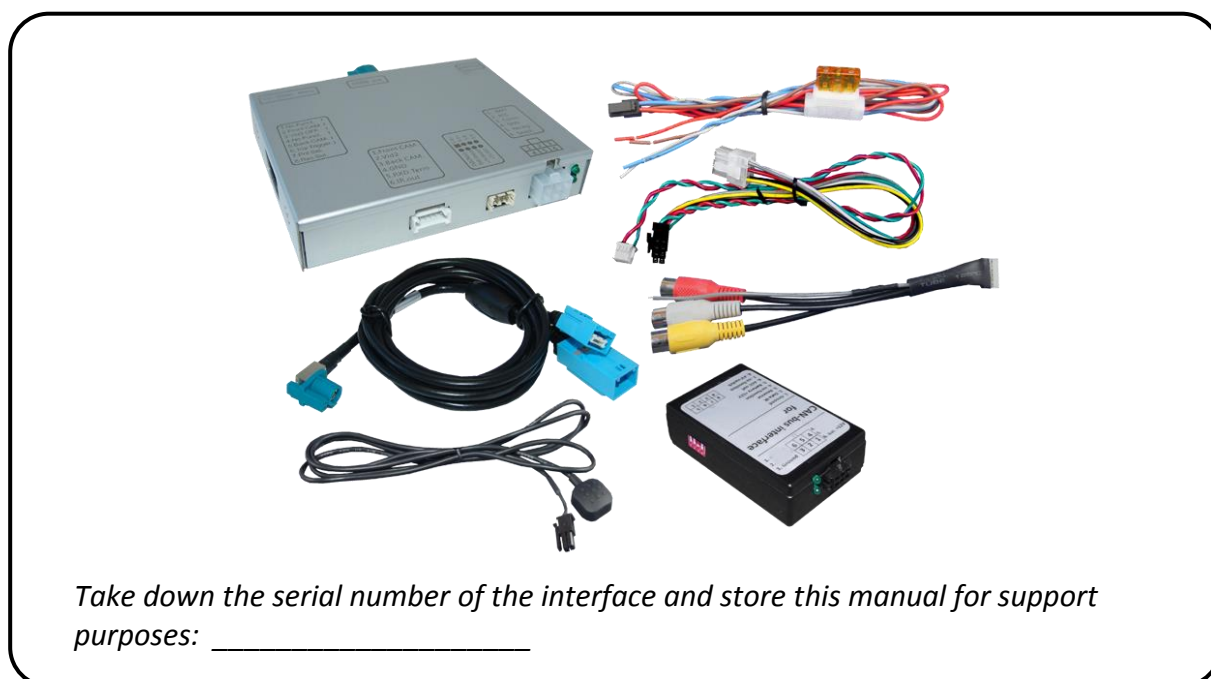

## 1.2. Checking the compatibility of vehicle and accessories

Requirements		
brand	compatible vehicles	Navi/radio
<b>Buick</b>	LaCrosse, Regal-	DVD800/CD500
<b>Chevrolet</b>	Cruz, Orlando	DVD900/DVD600
<b>Opel</b>	Astra J, Insignia A, Meriva B and other vehicles till about model year 2011	DVD800/CD500
	Astra J, Cascada, GTC, Insignia A,, Meriva B, Mokka A and other vehicles, model years 2012-2013	DVD900, DVD600, DVD650, DVD950 intellilink, CD600 intelliLink

  

Limitations	
<i>Video only</i>	The interface inserts ONLY video signals into the infotainment. For inserting Audio signals either the possibly existing factory audio-AUX-input or a FM-modulator can be used. If 2 audio sources shall be connected to the infotainment, an additional electronic is necessary to switch them.
<i>Guide lines</i>	If the CAN-box does not receive the required information from the vehicle CAN-bus, the guide-lines will not be supported.
<i>Factory rear-view camera</i>	Automatically switching-back from inserted video to factory rear-view camera only while reverse gear is engaged. To delay the switch-back time, additional electronics is required.
<i>AV input signal</i>	only NTSC compatible

## 1.3. Boxes and connectors

### 1.3.1. Video-interface

The video-interface converts the video signals of connected after-market sources in a factory monitor compatible picture signal which is inserted in the factory monitor, by using separate trigger options. Further it reads the vehicle's digital signals out of the vehicle's CAN-bus and converts them for the video interface.

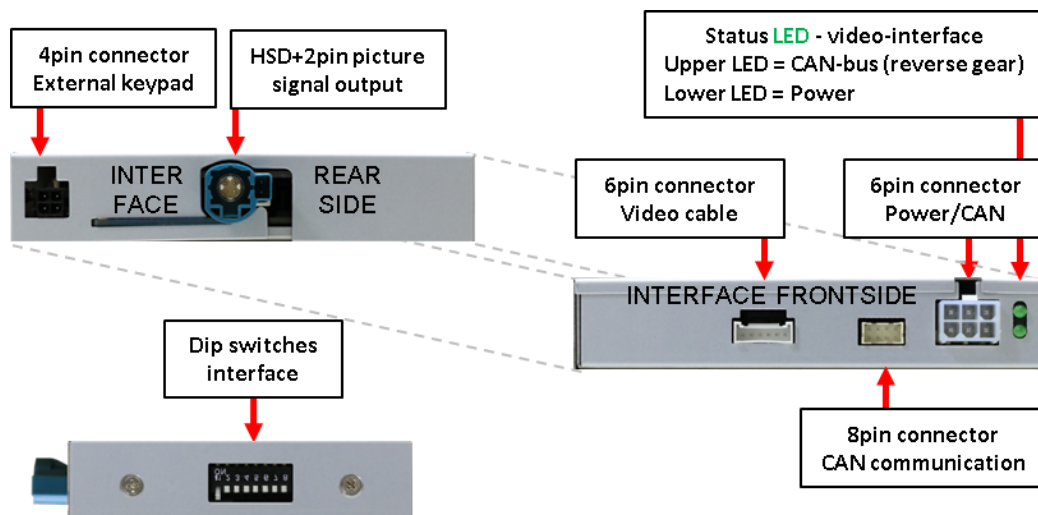

## 1.3.2. CAN box

The CAN box reads out the digital signals from the vehicle CAN bus and converts them for the video-interface.

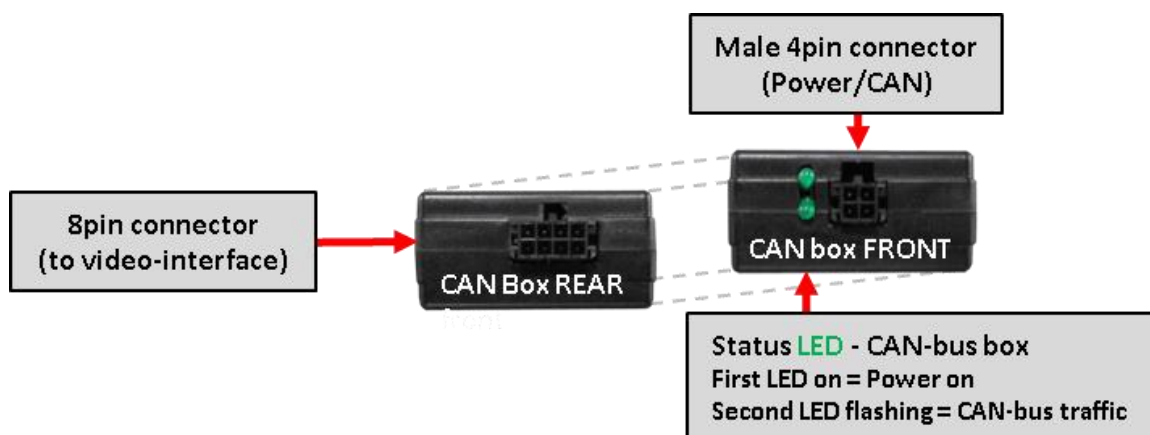

## 1.4. Dip-switch settings at the video interface

Some settings must be selected by the dip-switches on the video interface. Dip position down is ON and position up is OFF.



Dip	Function	ON (down)	OFF (up)
1	No function	-	set to OFF
2	CVBS AV1-input	enabled	disabled
3	CVBS AV2-input	enabled	disabled
4	No function	-	set to OFF
5	Rear-view cam type	after-market	factory or none
6	Monitor selection	Try all possible combinations of dip 6-8 to find the best picture (quality and size)	
7			
8			

**After each Dip-switch-change a power-reset of the Can-box has to be performed!**

See following chapters for detailed information.

## 1.4.1. Enabling the interface's video inputs (dip 2-3)

Only the enabled video inputs can be accessed by switching through the interface's video sources. It is recommended to enable only the required inputs. So the disabled inputs will be skipped while switching through the video interfaces inputs.

## 1.4.2. Rear-view camera setting (dip 5)

If set to OFF, the interface switches to factory picture while the reverse gear is engaged to display factory rear-view camera.

If set to ON, the interface switches to its rear-view camera input „**Camera-IN**“ while the reverse gear is engaged.

## 1.4.3. Monitor selection (dips 6-8)

Dips 6-8 are for monitor-specific picture settings which cannot be predicted, as even within the same head-unit version the monitor specifications may vary. It is necessary to try all possible combinations while a working video source is connected to the chosen input of the interface, to see which combination gives the best picture quality and size (some may give no picture). It is possible to first hot plug through the dip combinations, but if you do not experience any change of picture after trying all options, retry and disconnected the 6pin power plug of the video-box between every change of the dip setting.

**Note:** Dip 1 and 4 are out of function and have to be set to **OFF**.

## 2. Installation

**To install the interface, first switch off the ignition and disconnect the vehicle's battery. Please read the owner`s manual of the car, regarding the battery`s disconnection! If required, enable the car`s Sleep-mode (hibernation mode)  
In case the sleep-mode does not succeed, the disconnection of the battery can be done with a resistor lead.  
If the necessary stabilized power supply for the interface is not taken directly from the battery, the chosen connection has to be checked for being constantly stabile.  
The interface needs a permanent 12V source!**

Note: Before a final installation, we recommend a test-run to ensure the compatibility of the vehicle and the interface. Due to changes in the production of the vehicle manufacturer there's always a possibility of incompatibility.

### 2.1. Place of Installation

The interface is performed to be installed on the backside of the factory monitor and on the backside of the head-unit.

## 2.2. Connection schema

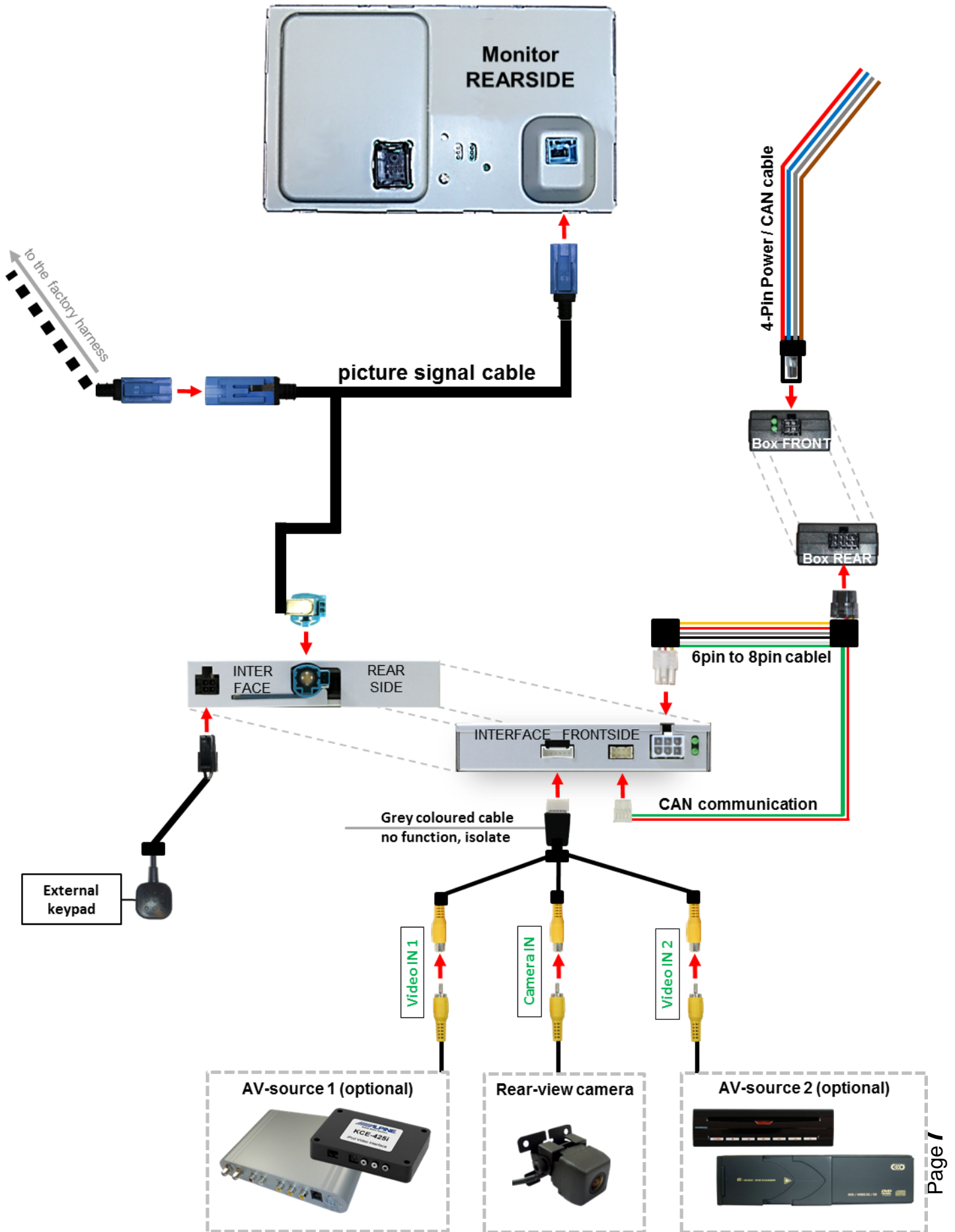

## 2.3. Connecting video-interface and CAN box

The CAN box reads out the digital signals from the GM-LAN and converts them for the video-interface. ACC +12V max. 0.5A (red of 6pin) and reverse gear +12V max. 0.5A (green of 6pin) constant signal. Video-source switching (white of 6pin) as +12V impulse.

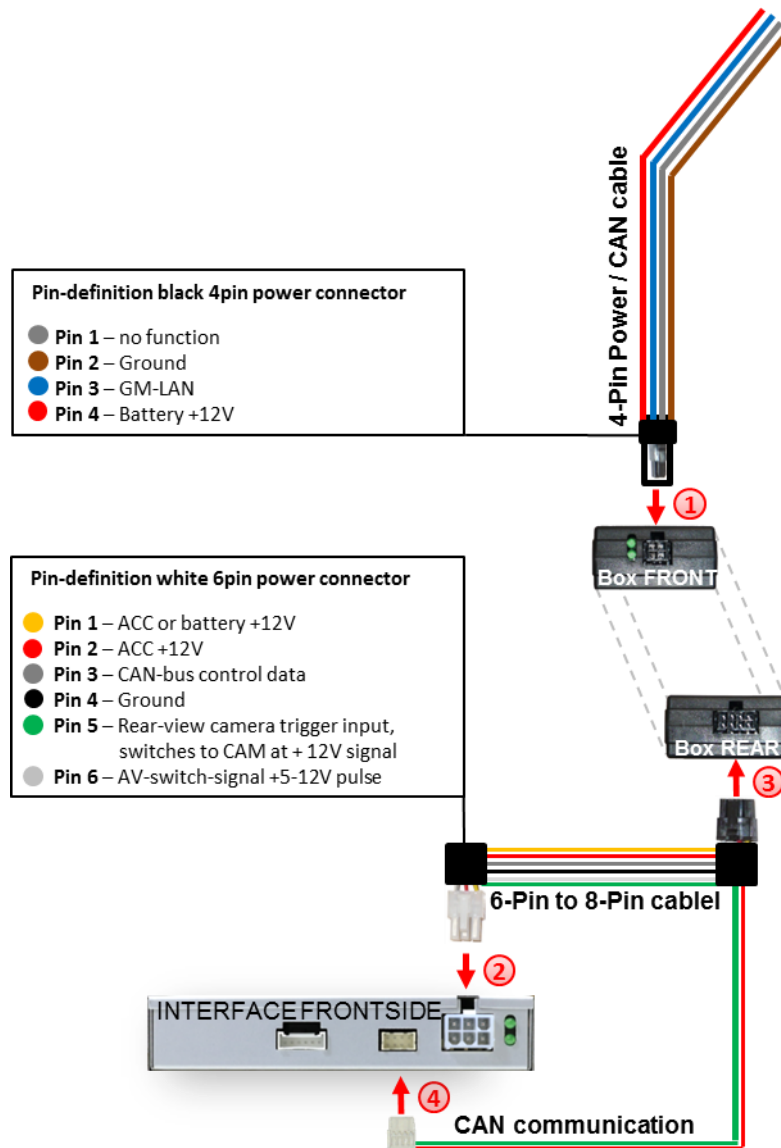

- 1 Connect the black female 4pin connector of the 4pin cable to the male 4pin connector of the CAN box.
- 2 Connect white female 6pin connector of the 6pin to 8pin cable to the male 6pin connector of the video-interface.
- 3 Connect black female 8pin connector of the 6pin to 8pin cable to the male 8pin connector of the CAN box.
- 4 Connect red-green drilled cable of the 6pin of 8pin cable to the male 4pin connector of the video-interface.



## 2.4. Connection CAN box - Quadlock

**GM-LAN – Pin 28  
(alternative Pin 14)**  
The GM-LAN wire of the  
vehicle harness is  
Usually green.

**+12V Battery – Pin 44**

**Ground – Pin 38**

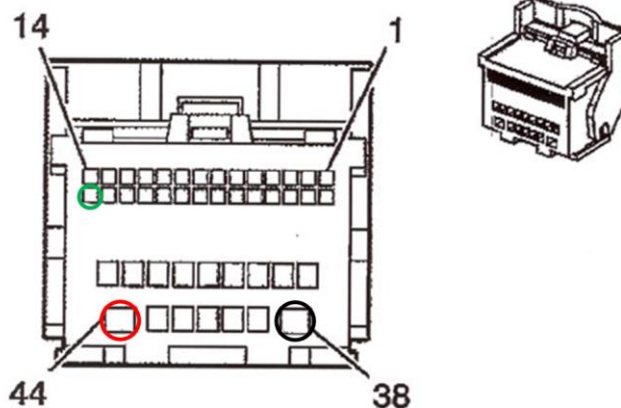

Pin definition female vehicle connector

Connect the 4pin cable to +12V Battery, Ground and GM-LAN at the vehicle's female Quadlock connector behind the head-unit, as shown in the picture.

Check LEDs on GM-LAN-box after reconnecting the battery, one must be on. GM-LAN position can be different on certain vehicles

**Note:** The CAN box is not compatible with all vehicles. If the CAN box does not receive ACC to pin2 of the video-interface or blocks the vehicle's CAN bus, it is possible to install the interface without the CAN box. In this case see also note in chapter "after-market rear-view camera" how to connect the interface without the CAN box.

## 2.5. Connections to the factory monitor

Remove factory monitor.

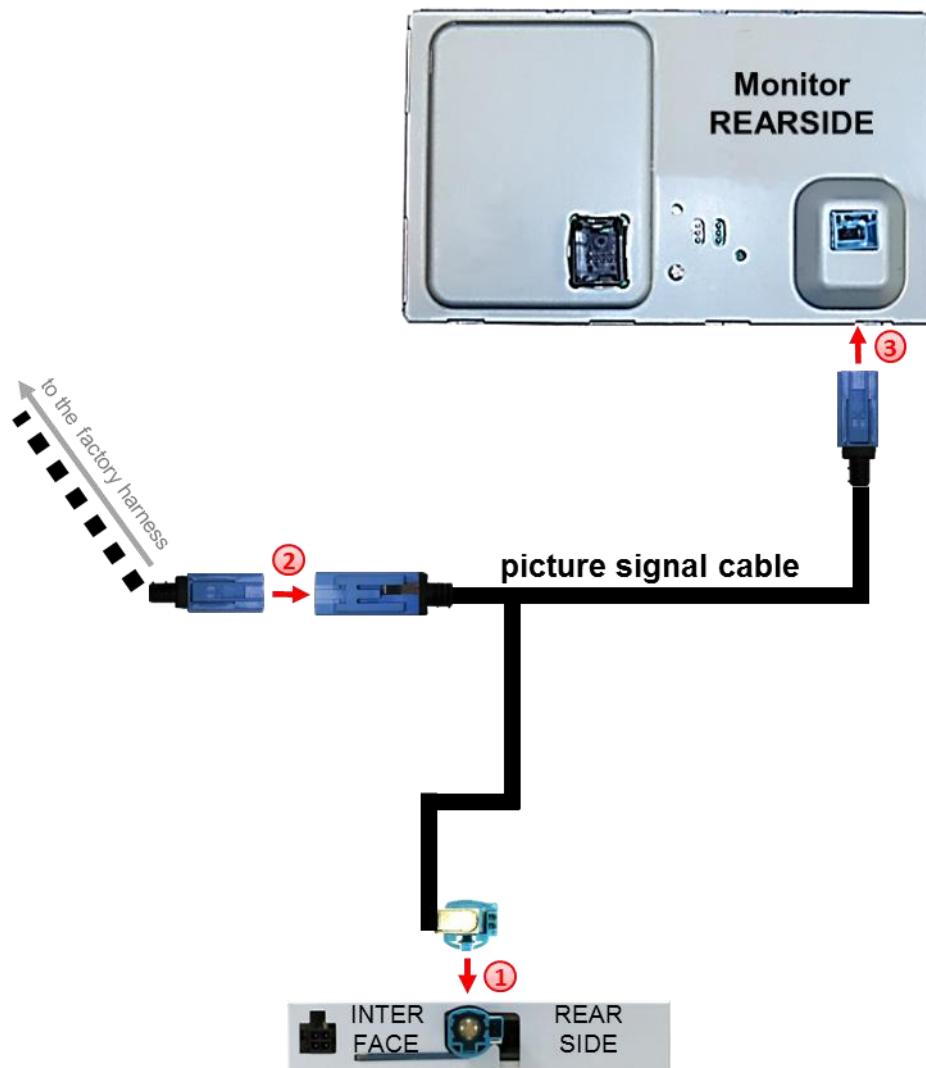

- 1 Connect female HSD+2pin connector of the picture signal cable to the male HSD+2pin connector on the rear-side of the interface.
- 2 Remove the female GVI connector from the rear-side of the factory monitor and connect it to the male GVI connector of the picture signal cable.
- 3 Connect female GVI connector of the picture signal cable to the male GVI connector of the factory monitor.

## 2.6. Connecting video sources

It is possible to connect one after-market rear-view camera and two more AV sources to the video-interface.

**Note:** Before a final installation, we recommend a test-run to ensure the compatibility of the vehicle and the interface. Due to changes in the production of the vehicle manufacturer there's always a possibility of incompatibility.

### 2.6.1. After market rear-view camera

Some vehicles have a different reverse gear code on the Can-Bus, which is not compatible with the CAN-Box included in the scope of delivery. For this reason there are two possibilities of installation. If the Can-Box receives the reverse gear signal, the green wire of the 6Pin to 8pin cable is occupied by +12V, as long as the reverse gear is engaged.

**Note:** Before testing, please don't forget to shift the Dip 5 of the Video Interface to ON.

#### 2.6.1.1. Case 1: CAN box receives the reverse gear signal

In case the CAN box receives +12V on the green wire of the 6Pin to 8pin cable while reverse gear is engaged, the interface switches automatically switch to "Camera IN" input when the reverse gear is engaged.

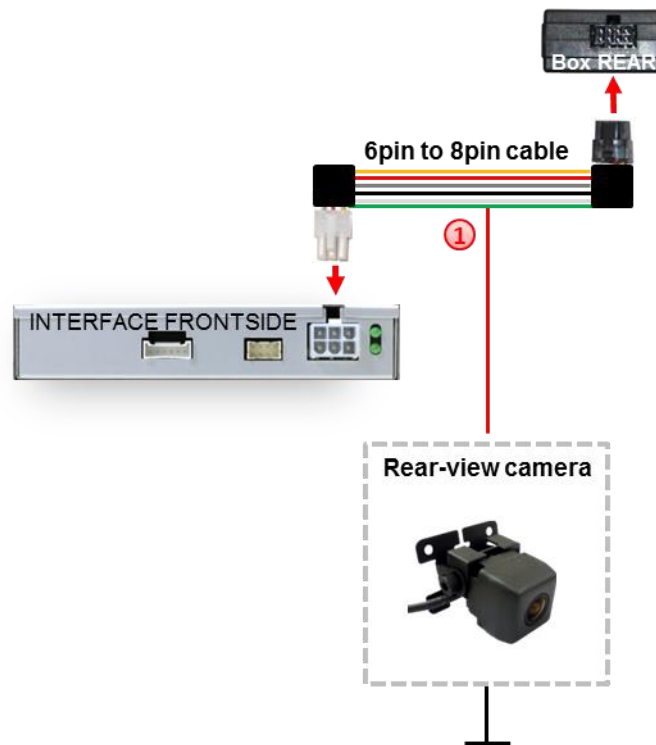

- ① In addition the power supply of +12V (500mA max.) of the after-market rear view camera can be realised by the green wire of of 6pin to 8pin cable.

## 2.6.1.2. Case 2: CAN box does not receive the reverse gear signal (e.g. Zafira2017)

If the Can box does not does not receive +12V on the green wire of the 6 to 8pin cable when reverse gear is engaged (not all vehicles are compatible), an external switching signal from the reverse gear light is required. As the reverse gear light's power supply isn't voltage-stable all the time, an ordinary open relay (e.g AC-RW-1230 with wiring AC-RS5) or filter (e.g. AC-PNF-RVC) is required. The diagram below shows the connection type of the relay.

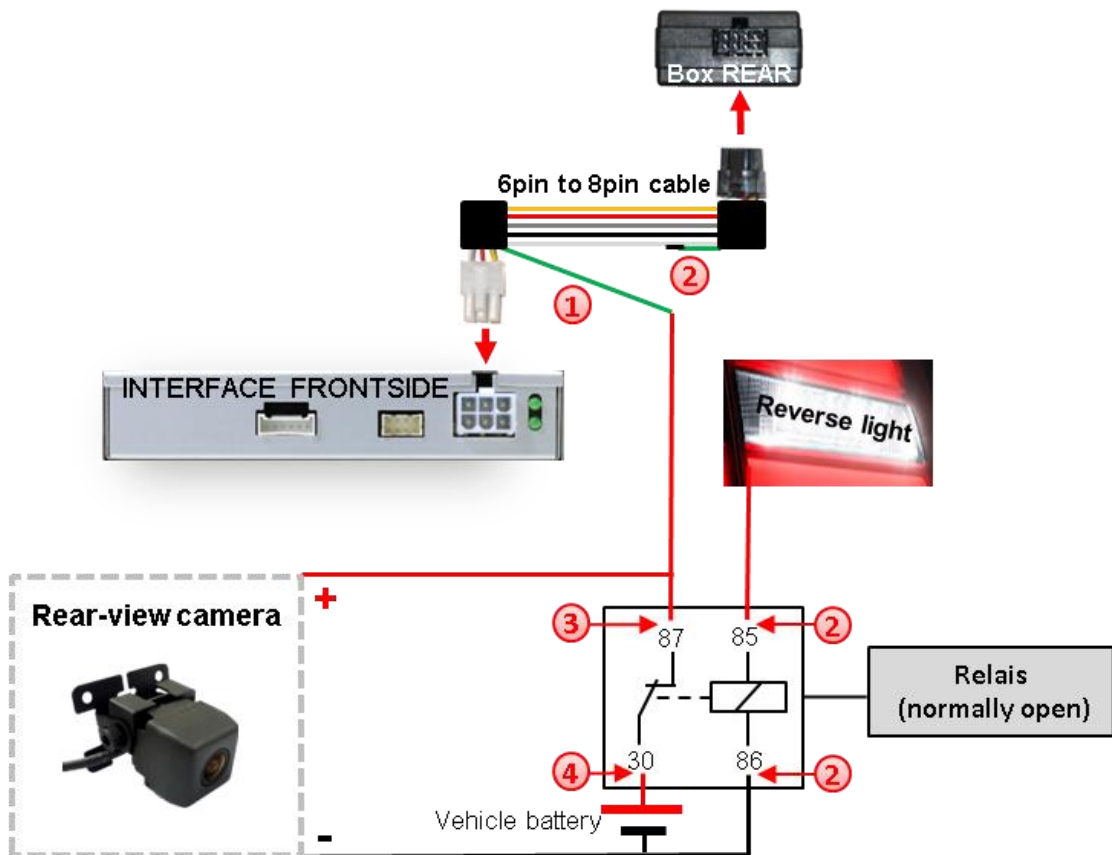

- 1** Cut the green cable of 6pin to 8pin cable near the black 8pin connector, isolate the short end (CAN box side) and connect the longer part of that cable to the output connector (87) of the relay.
- 2** Connect the Reverse light's power-cable to coil (85) and the vehicle's ground to coil (86) of the relay.
- 3** Connect the output connector (87) of the relay to the rear-view camera's power-cable, like you did it with the green cable before.
- 4** Connect permanent power +12V to the relay's input connector (30).

## 2.6.1.3. Video Signal Connection to Rear View Camera

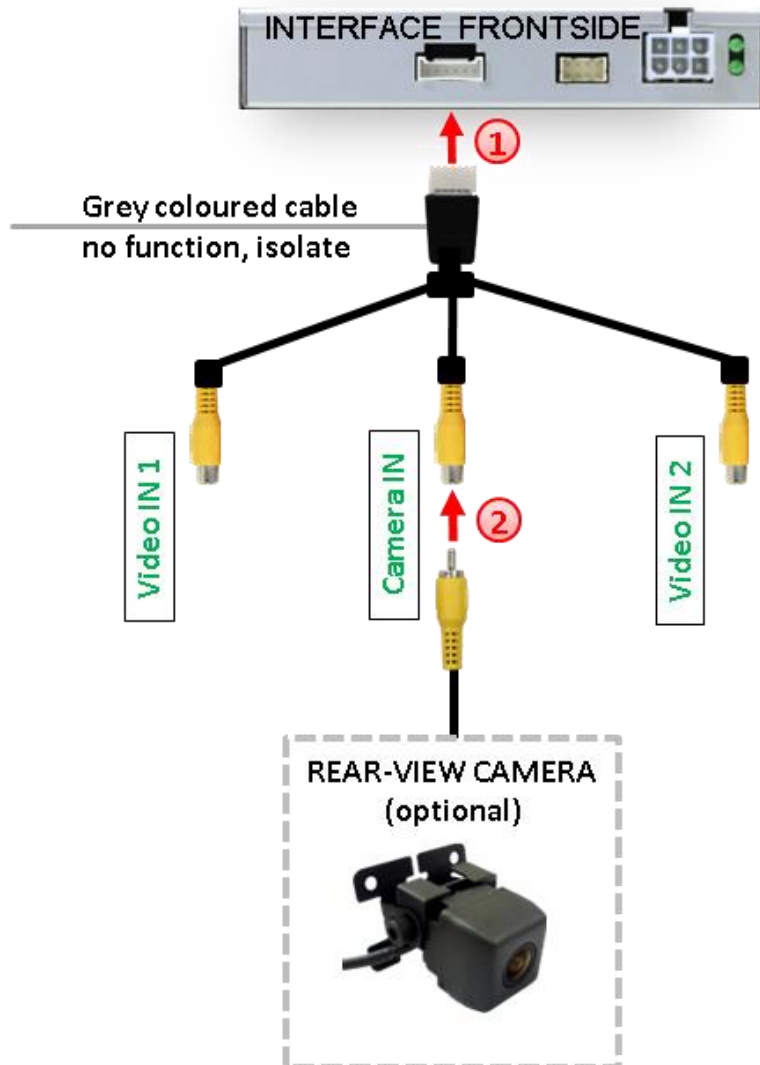

- ① Connect the video cable's female 6pin connector to the 6pin connector of the video interface
- ② Connect the video-RCA connector of the after-market rear-view camera to the female RCA port of the video-interface "Camera IN".

## 2.6.2. Connecting video source 1 and video source 2

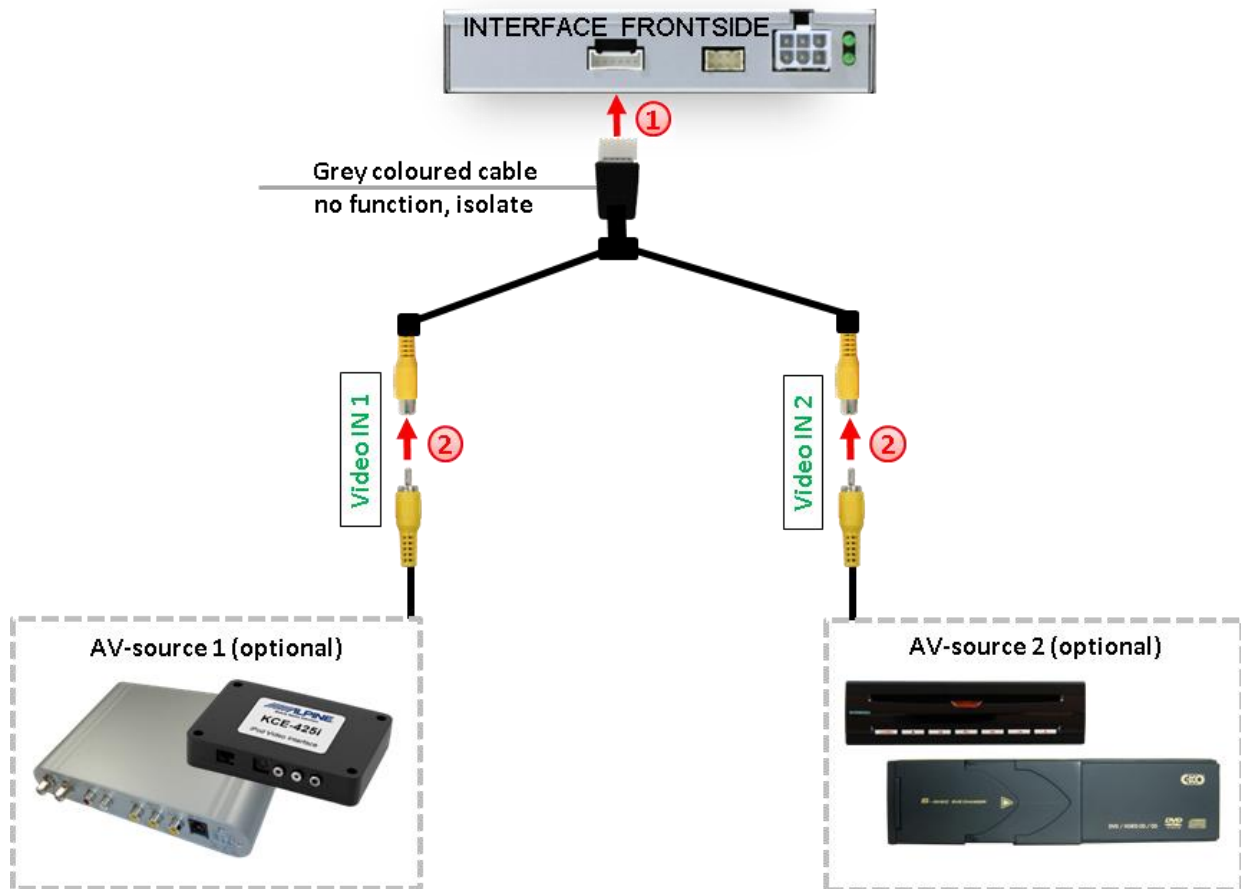

- 1 Connect 6pin male connector of the video cable to the 6pin female connector of the video interface.
- 2 Connect male RCA connector of video source 1 to the white coloured female RCA connector „Video IN1“ and connect the male RCA connector of video source 2 to the yellow coloured female RCA connector „Video IN2“ of video Cable.

## 2.6.3. Audio-Einspeisung

This interface can only insert video signals into the factory infotainment. If an AV-source is connected, audio insertion has to be done by factory audio AUX input or FM-modulator. The inserted video-signal can be activated simultaneously to each audio-mode of the factory infotainment.

## 2.7. Connection Video Interface and external keypad

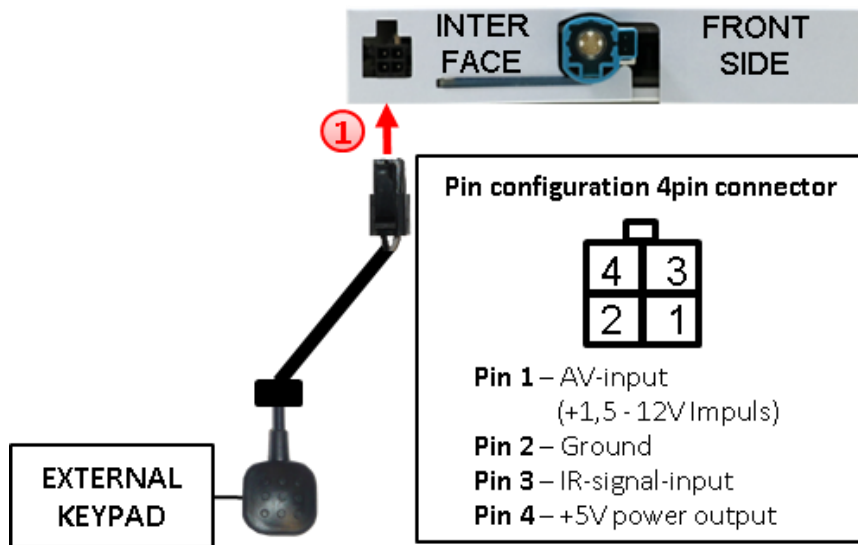

- 1 Connect the external keypad's female 4pin connector to the male 4pin connector of the video interface

## 2.8. Picture settings and guide lines

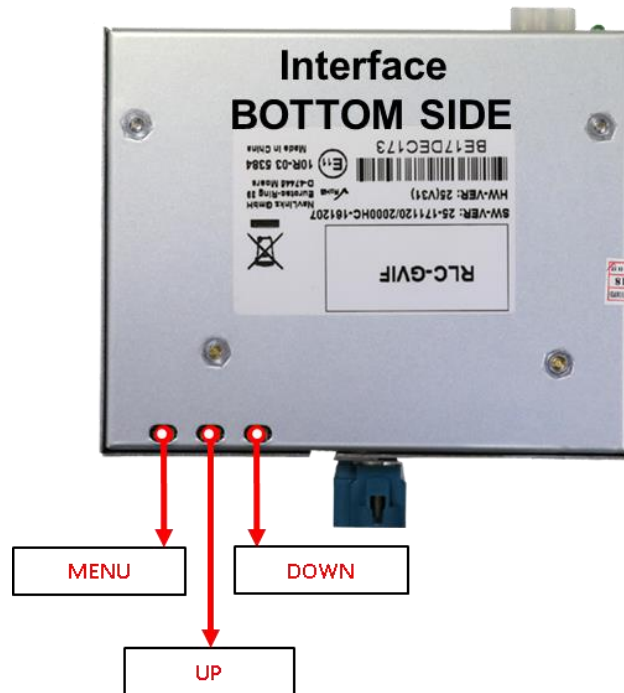

The picture settings are adjusted by the 3 buttons on the video-interface. Press the MENU button to open the OSD settings menu or to switch to the next menu item. Press UP and DOWN change the selected value. The buttons are embedded in the housing to avoid accidental changes during or after installation. Picture settings must be done separately for RGB, AV1 and AV2 while the corresponding input is selected and visible on the monitor. AV2 and CAM share the same settings which must be adjusted in AV2.

**Note:** The OSD menu is only shown when a working video source is connected to the selected video-input of the video interface.

The following settings are available:

- Brightness
- Contrast
- Saturation
- Position H (horizontal)
- Position V (vertical)
- GVIF year
- UI-CNT = activation of guide lines

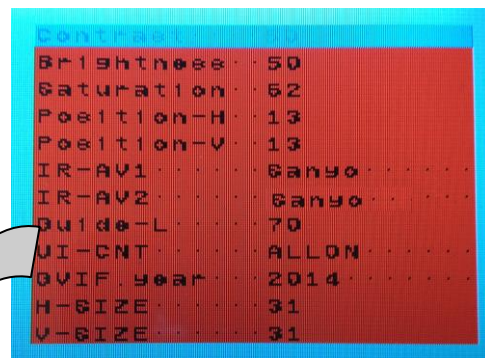

### Options:

- All ON:** Guide lines and PDC will be displayed.
- PDC ON:** Only PDC displayed.
- Guide ON:** Only Guide lines displayed.
- ALL Off:** Guide lines and PDC will not be displayed.

**Note:** If the CAN box does not support the vehicle, the guide-lines cannot be used.



## 3. Interface operation

### 3.1. By “hang-up” key

The “hang-up”-button on the steering-wheel can be used to execute interface functions.

Press “hang-up”-button on the steering-wheel longer than 1 sec to switch the video-source.

Each press will switch to the next enabled input. Inputs which are not enabled are skipped.

**Switchover by vehicle buttons isn't possible in all vehicles. In some vehicles the external keypad must be used.**

**Note:** Alternatively the white wire of the 6pin cable can be used with a +5-12V pulse to switch the video-sources alternatively.

### 3.2. By keypad

Alternatively or additionally to the factory infotainment buttons the interface's external keypad can be used to switch the enabled inputs.

## 4. Specifications

BATT/ACC range	7V - 25V
Stand-by power drain	3mA
Power consumption	167mA
Video input	0.7V - 1V
Video input formats	NTSC
Temperature range	-40°C to +85°C
Dimensions video-box	113 x 22 x 107 mm (W x H x D)
Dimensions CAN-box	73 x 22 x 42 mm (W x H x D)

## 5. FAQ – Trouble shooting Interface functions

For any troubles which may occur, check the following table for a solution before requesting support from your vendor.

Symptom	Reason	Possible solution
No picture/black picture (factory picture).	Not all connectors have been reconnected to factory head-unit or monitor after installation.	Connect missing connectors.
	No power on CAN-bus box (all LED CAN-bus box are off).	Check power supply of CAN-bus box. Check CAN-bus connection of CAN-bus box.
	CAN-bus box connected to CAN-bus in wrong place.	Refer to the manual where to connected to the CAN-bus. If not mentioned, try another place to connect to the CAN-bus.
	No power on video-interface (all LED video-interface are off).	Check whether CAN-bus box delivers +12V ACC on red wire output of 8pin to 6pin cable. If not cut wire and supply ACC +12V directly to video-interface.
No picture/black picture/white picture (inserted picture) but factory picture is OK.	No picture from video source.	Check on other monitor whether video source is OK.
	No video-source connected to the selected interface input.	Check settings dips 1 to 3 of video interface which inputs are activated and switch to corresponding input(s).
	LVDS cables plugged in wrong place.	Double-check whether order of LVDS cables is exactly connected according to manual. Plugging into head-unit does not work when the manual says to plug into monitor and vice versa.
Inserted picture totally wrong size or position.	Wrong monitor settings of video-interface.	Try different combinations of dips 7 and 8 of video-interface. Unplug 6pin power after each change.
Inserted picture double or 4 times on monitor.		
Inserted picture distorted, flickering or running vertically.	Video sources output set to AUTO or MULTI which causes a conflict with the interfaces auto detection.	Set video source output fixed to PAL or NTSC. It is best to set all video sources to the same standard.
	If error occurs only after source switching: Connected sources are not set to the same TV standard.	Set all video sources to the same standard.
	Some interfaces can only handle NTSC input.	Check manual whether there is a limitation to NTSC mentioned. If yes, set source fixed to NTSC output.
Inserted picture b/w.	Picture settings have not been adjusted.	Use the 3 buttons and the interface's OSD to adjust the picture settings for the corresponding video input.
Inserted picture qual. bad.		
Inserted picture size slightly wrong.		
Inserted picture position wrong.		
Camera input picture flickers.	Camera is being tested under fluorescent light which shines directly into the camera.	Test camera under natural light outside the garage.
Camera input picture is bluish.	Protection sticker not removed from camera lens.	Remove protection sticker from lens.

Symptom	Reason	Possible solution
Camera input picture black.	Camera power taken directly from reverse gear lamp.	Use relay or electronics to "clean" reverse gear lamp power. Alternatively, if CAN-bus box is compatible with the vehicle, camera power can be taken from green wire of 6pin to 8pin cable.
Camera input picture has distortion.		
Camera input picture settings cannot be adjusted.	Camera input picture settings can only be adjusted in AV2 mode.	Set dip 3 of video-interface to ON (if not input AV2 is not already activated) and connect the camera to AV2. Switch to AV2 and adjust settings. Reconnect camera to camera input and deactivate AV2 if not used for other source.
Graphics of a car in camera input picture.	Function PDC is ON in the interface OSD.	In compatible vehicles, the graphics will display the factory PDC distance. If not working or not wanted, set interface OSD menu item UI-CNTRL to ALLOFF.
Chinese signs in camera input picture	Function RET or ALL is ON (function for Asian market) in the interface OSD.	Set interface OSD menu item UI-CNTRL to ALLOFF or PDCON.
Not possible to switch video sources by OEM button.	CAN-bus interface does not support this function for vehicle.	Use external keypad or cut white wire of 6pin to 8pin cable and apply +12V impulses for AV-switching.
Not possible to switch video sources by external keypad.	Pressed too short.	For video source switching a longer press of about 2.5 seconds is required.
	SW-version of interface does not support external keypad.	Use OEM-button or cut white wire of 6pin to 8pin cable and apply +12V impulses for AV-switching.
Interface does not switch to camera input when reverse gear is engaged.	CAN-bus interface does not support this function for the vehicles.	Cut the green wire of the 6pin to 8pin cable and apply +12V constant from reverse gear-lamp signal. Use relay to "clean" R-gear lamp power.
Interface switches video-sources by itself.	CAN-bus interface compatibility to vehicle is limited.	Cut the grey wire of 6pin to 8pin and isolate both ends. If problem still occurs, additionally cut the white wire of 6pin to 8pin cable and isolate both ends.

## 6. Technical Support

Please note that direct technical support is only available for products purchased directly from NavLinkz GmbH. For products bought from other sources, contact your vendor for technical support.

**NavLinkz GmbH**  
**distribution/tech dealer-support**  
 Eurotec-Ring 39  
 D-47445 Moers

Tel +49 2841 949970  
 Email mail@navlinkz.de

 10R-03 5384

Made in China

